

# Amphenol-Air LB

SJT

VG96912

AA96912



Kompakter und robuster Rundsteckverbinder  
mit Bajonett Verriegelung  
zur Signal- und Daten-Übertragung

Compact and rugged circular connector  
with bayonet locking  
for signal and data transmission



**WE CONNECT THE WORLD AND BEYOND**

[www.amphenol-airlb.de](http://www.amphenol-airlb.de) | [info@amphenol-airlb.de](mailto:info@amphenol-airlb.de)

<b>General information</b>	<b>1</b>
Technical Data	<b>2-3</b>
Coding	<b>4</b>
Contact arrangements	<b>5-7</b>
Cross-reference table	<b>8</b>
SJT RT (crimp connection)	<b>10-14</b>
SJT Y (solder connection, hermetically sealed)	<b>15-17</b>
SJT GS (PCB connection) SJT WW (wire-wrap connection)	<b>18-24</b>
Accessories	<b>25-36</b>
Tools	<b>37-38</b>
Assembly instructions	<b>39-54</b>

### **Safety information**

Our products are constantly being developed and improved. Therefore, we reserve the right to change designs for quality improvements, enhancements, or manufacturing needs.

All technical specifications concern connectors, which is equipment that cannot be disconnected or separated under voltage.

AMPHENOL BEZEICHNUNG / DESIGNATION SJT

	SJT	G06	RT	14-35	P	N	029J	LC
<b>Baureihe / Series</b>								
<b>SJT</b>								
<b>Gehäuse Form / Shell style</b>								
<b>00</b>	Flanschsteckdose für Vorder- und Hinterwandmontage / Flange-receptacle for front- and rear panel mounting							
<b>P00</b>	Flanschsteckdose für Hinterwandmontage / Flange-receptacle for rear panel mounting							
<b>01</b>	Kabelverlängerungsdose / In-line receptacle							
<b>06</b>	Gerader Stecker / Straight plug							
<b>G06</b>	Gerader Stecker 360° HF dicht / Straight plug 360° RF shielded							
<b>07</b>	Einloch Steckdose für Hinterwandmontage / Jam-Nut receptacle for rear panel mounting							
<b>I*</b>	Steckdose mit Lötflansch / Receptacle with solder flange							
<b>Anschluss- Optionen / Termination options</b>								
<b>AB</b>	Leiterplattenkontakte, montiert / PCB-contacts, installed (Gehäuseform/shell style 00, Lötlänge / stickout length 5mm)							
<b>BA</b>	Leiterplattenkontakte, montiert / PCB-contacts, installed (Gehäuseform/shell style 07, Lötlänge / stickout length 4mm)							
<b>GS</b>	Leiterplattenkontakte (beiliegend) / PCB-contacts (enclosed) (Gehäuseform/shell style 00 - Lötlänge / stickout length 6,5mm) (Gehäuseform/shell style 07 - Lötlänge / stickout length 4mm)							
<b>RT</b>	Crimpkontakte / Crimp-contacts (Gehäuseform/shell style 00; P00; 01; 06; G06; 07)							
<b>WW</b>	Wickelkontakte / Wire-wrap-contacts (Gehäuseform/shell style 00; 07)							
<b>Y*</b>	Hermetisch dicht, Lötkontakte / Hermetically sealed, solder contacts (Gehäuseform/shell style 07; I)							
<b>Gehäusegröße &amp; Polbild / Shell size &amp; Contact arrangement</b>								
Siehe Katalog / see catalogue								
<b>Kontaktart / Contact type</b>								
<b>S</b>	Buchsenkontakt / Socket contact							
<b>P</b>	Stiftkontakt / Pin contact							
<b>Winkelstellung / Angular position</b>								
<b>N</b>	Normalstellung / Standard position							
<b>A / B / C / D</b>								
<b>Ausführung / Version</b>								
<b>014</b>	Aluminiumlegierung kadmiert / Aluminium alloy with cadmium plating							
<b>023</b>	Aluminiumlegierung vernickelt / Aluminium alloy nickel plated							
<b>029J</b>	Aluminiumlegierung, Oberfläche Zink-Zinn-beschichtet und/oder schwarz anodisiert / Aluminium alloy, surface zinc-tin coated and/or black anodized							
<b>F6</b>	Marine Bronze / Marine bronze							
<b>Modifikation / Modification</b>								
<b>LC</b>	ohne Kontakte / less contacts							
<b>M347</b>	mit montierten GS Kontakten / with installed GS contacts (Gehäuseform/shell style 00/07)							
<b>Mxxx</b>	Kundenspezifische Ausführung, auf Anfrage / customized solutions, on request							

\* SJTIY und SJT07Y sind nur in Ausführung Stahl verfügbar  
 SJTIY and SJT07Y are only available in version steel

AMPHENOL BEZEICHNUNG / DESIGNATION AA

	AA96912	D	14-35	S	N	1
<b>Amphenol Air LB Norm / Standard</b>						
<b>AA96912</b> - Aluminiumlegierung kadmiert / Aluminium alloy with cadmium plating						
<b>Gehäuse Form / Shell style</b>						
<b>A</b>	Flanschsteckdose für Vorder- und Hinterwandmontage, Crimpkontakte / Flange-receptacle for front- and rear panel mounting, crimpcontacts					
<b>AA</b>	Flanschsteckdose für Hinterwandmontage, Crimpkontakte / Flange-receptacle for rear panel mounting, crimpcontacts					
<b>AB</b>	Flanschsteckdose für Vorder- und Hinterwandmontage, Leiterplattenkontakte, montiert / Flange-receptacle for front- and rear panel mounting / PCB-contacts, installed (Lötlänge / stickout length 5mm)					
<b>B</b>	Einloch Steckdose für Hinterwandmontage, Crimpkontakte / Jam-nut receptacle for rear panel mounting crimpcontacts					
<b>BA</b>	Einloch Steckdose für Hinterwandmontage, Leiterplattenkontakte, montiert / Jam-nut receptacle for rear panel mounting PCB-contacts, installed (Lötlänge / stickout length 4mm)					
<b>D</b>	Gerader Stecker 360° HF dicht / Straight plug 360° RF shielded					
<b>E</b>	Gerader Stecker / Straight plug					
<b>X</b>	Kabelverlängerungsdose / In-line receptacle					
<b>Gehäusegröße &amp; Polbild / Shell size &amp; contact arrangement</b>						
Siehe Katalog / see catalogue						
<b>Kontaktart / Contact type</b>						
<b>S</b>	Buchsenkontakt / Socket contact					
<b>P</b>	Stiftkontakt / Pin contact					
<b>Winkelstellung / Angular position</b>						
<b>N</b>	Normalstellung / Standard position					
<b>A / B / C / D</b>						
<b>Lieferumfang / Scope of delivery</b>						
<b>Ohne Angabe / omit</b> - Mit Kontakten / with contacts						
<b>1</b>	ohne Kontakte / without contacts					

VG BEZEICHNUNG / DESIGNATION

	VG96912	D	14-35	S	N	1	J
<b>Norm / Standard</b>							
VG96912							
<b>Gehäuse Form / Shell style</b>							
<b>A</b>	Flanschsteckdose für Vorder- und Hinterwandmontage, Crimpkontakte / Flange-receptacle for front- and rear panel mounting, crimpcontacts						
<b>AA</b>	Flanschsteckdose für Hinterwandmontage, Crimpkontakte / Flange-receptacle for rear panel mounting, crimpcontacts						
<b>AB</b>	Flanschsteckdose für Vorder- und Hinterwandmontage, Leiterplattenkontakte, montiert / Flange-receptacle for front- and rear panel mounting / PCB-contacts, installed (Lötlänge / stickout length 5mm)						
<b>B</b>	Einloch Steckdose für Hinterwandmontage, Crimpkontakte / Jam-nut receptacle for rear panel mounting crimpcontacts						
<b>BA</b>	Einloch Steckdose für Hinterwandmontage, Leiterplattenkontakte, montiert / Jam-nut receptacle for rear panel mounting PCB-contacts, installed (Lötlänge / stickout length 4mm)						
<b>C</b>	Steckdose mit Lötflansch, hermetisch dicht, Lötkontakte / Receptacle with solder flange, hermetically sealed, solder contacts						
<b>D</b>	Gerader Stecker 360° HF dicht / Straight plug 360° RF shielded						
<b>E</b>	Gerader Stecker / Straight plug						
<b>X</b>	Kabelverlängerungsdose / In-line receptacle						
<b>Gehäusegröße &amp; Polbild / Shell size &amp; contact arrangement</b>							
Siehe Katalog / see catalogue							
<b>Kontaktart / Contact type</b>							
<b>S</b>	Buchsenkontakt / Socket contact						
<b>P</b>	Stiftkontakt / Pin contact						
<b>Winkelstellung / Angular position</b>							
<b>N</b>	Normalstellung / Standard position						
<b>A / B / C / D</b>							
<b>Lieferumfang / Scope of delivery</b>							
<b>Ohne Angabe / omit</b> - Mit Kontakten / with contacts							
<b>1</b>	ohne Kontakte / without contacts						
<b>Ausführung / Version</b>							
<b>J</b>	Aluminiumlegierung, Oberfläche Zink-Zinn-beschichtet und/oder schwarz anodisiert / Aluminium alloy, surface zinc-tin coated and/or black anodized						
<b>B</b>	Marine Bronze / Marine bronze						
<b>S2</b>	Stahl (für Bauform C) / Steel (for Shell style C)						

AMPHENOL BEZEICHNUNG / DESIGNATION AA

**Endgehäuse / Backshells**

AA96912

L

012

**Amphenol Air LB norm / Standard**

AA96912 - Aluminiumlegierung cadmiert / Aluminium alloy, cadmium plated

**Endgehäuse Form / Backshell style**

**F1-** Formteiladapter / Shrink boot adapter

**L** Klemmkonus / Clamping cone „SQ“

**M** Bandadapter / Bandadapter

**Teilenummer / Dash number**

Siehe Katalog / See catalogue



**Kappen / Caps**

AA96912

V3-

18

B

**Amphenol Air LB norm / Standard**

AA96912 - Aluminiumlegierung cadmiert / Aluminium alloy, cadmium plated

**Kappe Form / Cap style**

**V3-** Kappe für Stecker / Cap for plug

**V1-** Kappe für Flansch-Steckdose / Cap for flange receptacle

**V2-** Kappe für Einloch-Steckdose / Cap for jam nut receptacle

**Teilenummer / Dash number**

Siehe Katalog / see catalogue

**Befestigungsart / Attachment type**

**A** Kette / Chain

**B** Schnur / Cord

VG BEZEICHNUNG / DESIGNATION

Endgehäuse / Backshells

VG96912

L

012

J

Norm / Standard

VG96912

Endgehäuse Form / Backshell style

F1- Formteiladapter / Shrink boot adapter

L Klemmkonus / Clamping cone „SQ“

M Bandadapter / Bandadapter

Teilenummer / Dash number

Siehe Katalog / See catalogue

Ausführung / Version

J Aluminiumlegierung, Oberfläche Zink-Zinn-beschichtet und/oder schwarz anodisiert / Aluminium alloy, surface zinc-tin coated and/or black anodized

B Marine Bronze / Marine bronze



Kappen / Caps

VG96912

V3-

18

B

J

Norm / Standard

VG96912

Kappe Form / Cap style

V3- Kappe für Stecker / Cap for plug

V1- Kappe für Flansch-Steckdose / Cap for flange receptacle

V2- Kappe für Einloch-Steckdose / Cap for jam nut receptacle

Teilenummer / Dash number

Siehe Katalog / See catalogue

Befestigungsart / Attachment type

A Kette / Chain

B Schnur / Cord

Ausführung / Version

J Aluminiumlegierung, Oberfläche Zink-Zinn-beschichtet / Aluminium alloy, with zinc-tin plating

B Marine Bronze / Marine bronze



AMPHENOL BEZEICHNUNG / DESIGNATION SJT

Kappen / Caps

38824-07

6

-029J

Mxxxx

Kappen Form / Cap style

- 38822-07** Kappe mit Kette für Flanschsteckdose / Cap with chain for flange receptacle
- 38828-07** Kappe mit Schnur für Flanschsteckdose / Cap with rope for flange receptacle
- 42160-07** Kappe mit Kette für Stecker / Cap with chain for plug
- 42162-07** Kappe mit Schnur für Stecker / Cap with rope for plug
- 38824-07** Kappe mit Kette für Einlochsteckdose / Cap with chain for jam nut receptacle
- 38826-07** Kappe mit Schnur für Einlochsteckdose / Cap with rope for jam nut receptacle

Gehäusegröße / Shellsize

Bezeichnung / Designation	1	2	3	4	5	6	7	8	9
Größe / Size	8	10	12	14	16	18	20	22	24

Ausführung / Version

- ohne Angabe / omit: Aluminiumlegierung cadmiert / Aluminium alloy cadmium plated
- 023** Aluminiumlegierung vernickelt / Aluminium alloy nickel plated
- F6** Marine Bronze / Marine bronze
- 029J** Aluminiumlegierung, Oberfläche Zink-Zinn-beschichtet / Aluminium alloy, with zinc-tin plating

Modifikation / Modification

- Mxxxx** Kundenspezifische Ausführung, auf Anfrage / customized solutions, on request



AMPHENOL BEZEICHNUNG / DESIGNATION AA

Kappen / Caps

AA96912

V3-

18

B

Herstellernorm / Manufacturer standard

**AA96912** - Aluminiumlegierung cadmiert / Aluminium alloy, cadmium plated

Kappe Form / Cap style

- V3-** Kappe für Stecker / Cap for plug
- V1-** Kappe für Flansch-Steckdose / Cap for flange receptacle
- V2-** Kappe für Einloch-Steckdose / Cap for jam nut receptacle

Teilenummer / Dash number

Siehe Katalog / see catalogue

Befestigungsart / Attachment type

- A** Kette / Chain
- B** Schnur / Rope

**VG BEZEICHNUNG / DESIGNATION**

**Kappen / Caps**

**VG96912 V3- 18 B J**

**Norm / Standard**

**VG96912**

**Kappe Form / Cap style**

- V3-** Kappe für Stecker / Cap for plug
- V1-** Kappe für Flansch-Steckdose / Cap for flange receptacle
- V2-** Kappe für Einloch-Steckdose / Cap for jam nut receptacle

**Teilenummer / Dash number**

Siehe Katalog / See catalogue

**Befestigungsart / Attachment type**

- A** Kette / Chain
- B** Schnur / Rope

**Ausführung / Version**

- J** Aluminiumlegierung, Oberfläche Zink-Zinn-beschichtet / Aluminium alloy, with zinc-tin plating
- B** Marine Bronze / Marine bronze

**PRODUKTÜBERSICHT KAPPEN / PRODUCT OVERVIEW CAPS**

<b>VG96912V1A</b> <b>AA96912V1A</b> <b>38822-07</b>	<b>VG96912V1B</b> <b>AA96912V1B</b> <b>38828-07</b>	<b>VG96912V3A</b> <b>AA96912V3A</b> <b>42160-07</b>	<b>VG96912V3B</b> <b>AA96912V3B</b> <b>42162-07</b>	<b>VG96912V2A</b> <b>AA96912V2A</b> <b>38824-07</b>	<b>VG96912V2B</b> <b>AA96912V2B</b> <b>38826-07</b>
Flanschsteckdose / Flange receptacle		Kabelstecker / Cable plug		Einlochsteckdose / Jam nut receptacle	
Kette / Chain	Schnur /Rope	Kette / Chain	Schnur /Rope	Kette / Chain	Schnur /Rope



#### **Plugs and receptacles in the SJT series**

- Contacts mechanically protected
- Grounding ring on plug (HF-tightness)
- Three pin bayonet coupling
- Non-interchangeable through coding
- High contact density

These miniature circular connectors of the SJT series adhere to the VG 96912 standard. They meet the requirements of specification PAN 6433-2, and have all essential features of connectors specified according to MIL-C-38999. They feature 100% contact protection (scoop-proof), high contact density and HF-tightness.

The Amphenol-Air LB SJT series are approved:  
as per VG 96912 under No. 332 (84)  
as per PAN 6433-2 under DDP No. MP 466

The environment-resistant connectors of this series are available with crimp contacts, dip solder contacts for printed circuit boards, and wire-wrap contacts. In addition, the series contains hermetically sealed receptacles with solder contacts.

These connectors with three pin bayonet couplings are well-suited for new technologies in the industrial and military sectors as well as aerospace applications, where size, weight and reliability are of crucial importance.

Amphenol-Air LB GmbH manufactures the SJT series at its plant in Saarlouis.

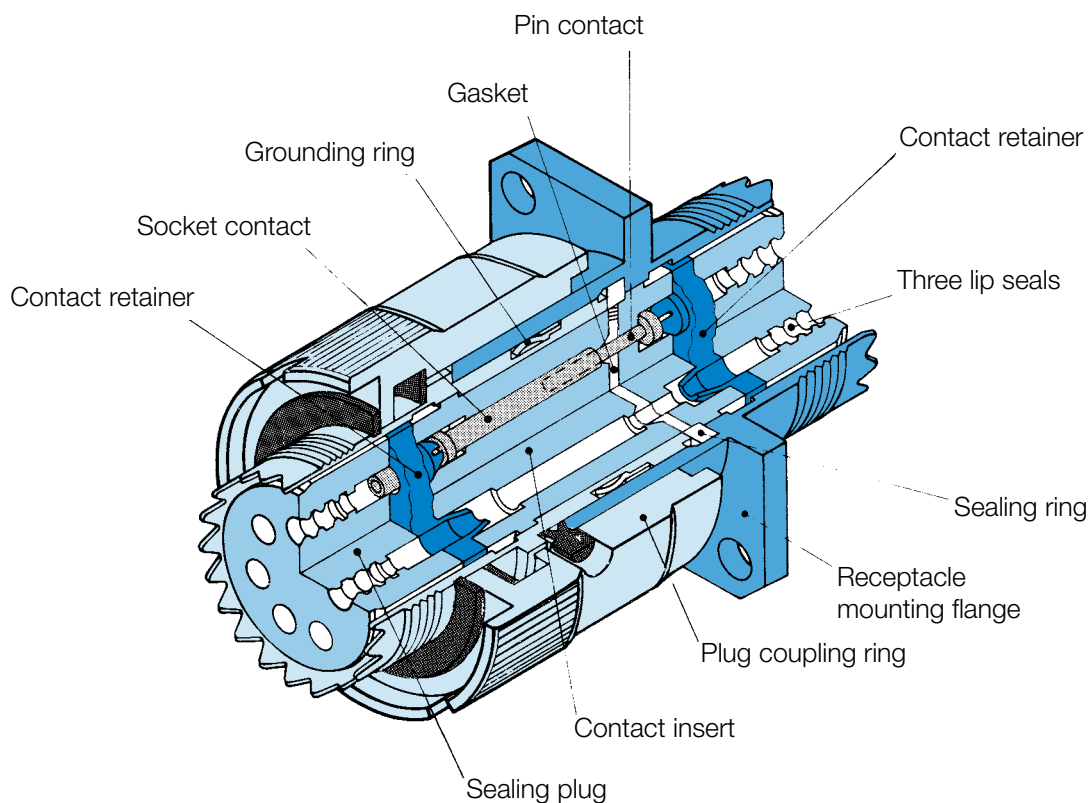

**Contact current load**

Contact size	Nominal current A		Test current A		Voltage drop at test current mV max.	
	Crimp contact	Solder contact (hermet.)	Crimp contact	Solder contact (hermet.)	Crimp contact	Solder contact (hermet.)
22D	5	3	5	3	40	85
20	7.5	5	7.5	5	35	60
16	13	10	13	10	25	85
12	23	17	23	17	25	85

**Operating voltage**

Voltage class *	Recommended max. operating voltage at sea level		Test voltage (eff.)			
	AC voltage (eff.) V	DC voltage V	Sea level V (coupled or disconnected)	15 000m V (coupled)	20 000m V (coupled)	30 000m V (coupled)
M	400	550	1300	800	800	800
I	600	850	1800	1000	1000	1000
II	900	1250	2300	1000	1000	1000

\* Contact arrangements are divided into the voltage classes M, I, and II, depending on contact distance and size (pages 5, 6 and 7).

**Operating temperature/Insulation resistance**

Operating temperature	Insulation resistance	
-65° C to 175° C  (= ambient temperature + overheating due to current)	Moisture-proof version (crimp contacts)	5000 M $\Omega$ at room temperature 500 M $\Omega$ at maximum temperature
	Hermetically sealed version (solder contacts)	5000 M $\Omega$ at room temperature 50 M $\Omega$ at maximum temperature

**Contact resistance**

Contact size	Stranded wire gauge AWG	Test current A	Contact resistance m $\Omega$ max.
22D	28	1.5	46.7
	26	2	32.0
	24	3	23.3
	22	5	17.6
20	24	3	18.0
	22	5	12.4
	20	7.5	8.8
16	20	7.5	7.3
	18	10	5.3
	16	13	4.5
12	14	17	2.5
	12	23	2.0

**Contact information**

Contact size	Dimensions of crimp sleeves		Strip length of conductor mm	
	Inner-Ø mm	Depth mm	min.	max.
22D	0.88 ± 0.03	3.6	3.5	4.0
20	1.19 ± 0.03	5.3	5.6	6.4
16	1.70 ± 0.03	5.3	5.6	6.4
12	2.54 ± 0.05	5.3	5.6	6.4

**Connection data**

Contact size	Stranded wire gauge AWG	Conductor cross-section (mm <sup>2</sup> copper cross-section)	Strand type Single wire X AWG	Insulation outer diameter	
				mm min. *	mm max.
22D	28	△ 0.09	7 x 36	0.80	1.50
	26	△ 0.15	7 x 34		
	24	△ 0.24	19 x 36		
	22	△ 0.38	19 x 34		
20	24	△ 0.24	19 x 36	1.02	2.11
	22	△ 0.38	19 x 34		
	20	△ 0.62	19 x 32		
16	20	△ 0.62	19 x 32	1.65	2.77
	18	△ 0.96	19 x 30		
	16	△ 1.23	19 x 29		
12	14	△ 1.94	19 x 27	2.46	3.61
	12	△ 2.97	37 x 28		

\*) The minimum insulation diameter is necessary to ensure moisture protection.

**Coupling and decoupling**

Shell size	Coupling and decoupling	Decoupling
	Torque Nm max.	Torque Nm min.
8	0.90	0.12
10	1.36	0.12
12	1.81	0.23
14	2.26	0.46
16	2.71	0.46
18	3.16	0.46
20	3.62	0.69
22	4.07	0.80
24	4.07	0.80

**Recommended tightening torque for backshells**

Shell size	Torque Nm
8	4
10	6
12	8
14	10
16	10
18	13
20	13
22	13
24	13

} +0.5  
} ±1

**Contact holding force**

Contact size	Contact holding force (axial) N min.
22D	40
20	60
16	100
12	100

**Leak rate**

Coupled connector	< 4.5 X 10 <sup>-3</sup> cm <sup>3</sup> /s at 2 bar
Hermetically sealed connector	1 X 10 <sup>-7</sup> cm <sup>3</sup> /s at 1 bar

All connectors have five guide lugs and grooves. If polarization of connectors with the same size and same number of contacts is necessary, this is achieved with different angular positions (A to D) of the contact insert in relation to the main guide groove/lug, as seen in the figures below.

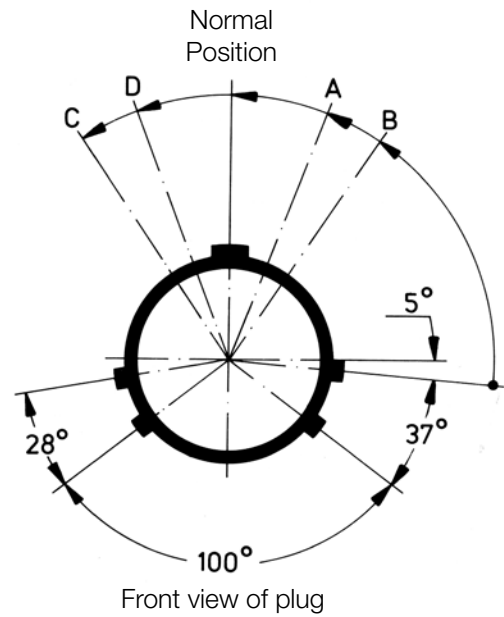
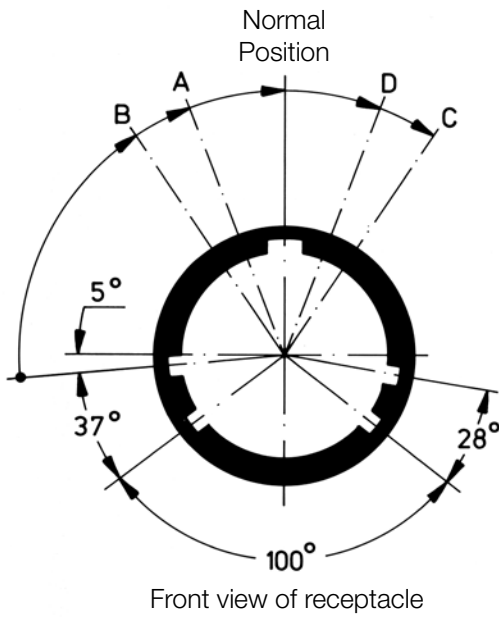

Shell size	Angular positions				
	Normal position	A	B	C	D
8	95°	77°	–	–	113°
10	95°	81°	67°	123°	109°
12	95°	75°	63°	127°	115°
14	95°	74°	61°	129°	116°
16	95°	77°	65°	125°	113°
18	95°	77°	65°	125°	113°
20	95°	77°	65°	125°	113°
22	95°	80°	69°	121°	110°
24	95°	80°	69°	121°	110°

## Overview

Shell size	Contact arrangement	Total number of contacts	Number of contacts per contact size				Voltage class *	Contact arrangements as per VG 96912
			22 D	20	16	12		
<b>8</b>	8-35	6	6				M	•
	8-98	3		3			I	•
<b>10</b>	10-35	13	13				M	•
	10-98	6		6			I	•
<b>12</b>	12-8	8		8			I	•
	12-35	22	22				M	•
	12-98	10		10			I	•
<b>14</b>	14-5	5			5		II	•
	14-18	18		18			I	•
	14-19	19		19			I	•
	14-35	37	37				M	•
	14-97	12		8	4		I	•
<b>16</b>	16-6	6				6	I	•
	16-8	8			8		II	•
	16-26	26		26			I	•
	16-35	55	55				M	•
	16-99	23		21	2		I	•
<b>18</b>	18-11	11			11		II	•
	18-32	32		32			I	•
	18-35	66	66				M	•
<b>20</b>	20-11	11				11	I	•
	20-16	16			16		II	•
	20-35	79	79				M	•
	20-39	39		37	2		I	
	20-41	41		41			I	•
<b>22</b>	22-21	21			21		II	•
	22-35	100	100				M	•
<b>24</b>	24-19	19				19	I	•
	24-29	29			29		I	•
	24-35	128	128				M	•
	24-61	61		61			I	•

Contact arrangements in hermetically sealed design or with coaxial contacts upon request.

\*See p. 2.

Ordering information inside front cover

**Contact symbols:**  12     16     20     22D

The following images show the front view of the pin insert and the back of the socket insert.





Image (contact arrangement)				
<b>Contact arrangement</b>	<b>8-35</b>	<b>8-98</b>	<b>10-35</b>	<b>10-98</b>
Number of contacts	6	3	13	6
Contact size	22 D	20	22 D	20
Voltage class	M	I	M	I

Image (contact arrangement)				
<b>Contact arrangement</b>	<b>12-8</b>	<b>12-35</b>	<b>12-98</b>	<b>14-5</b>
Number of contacts	8	22	10	5
Contact size	20	22 D	20	16
Voltage class	I	M	I	II

Image (contact arrangement)				
<b>Contact arrangement</b>	<b>14-18</b>	<b>14-19</b>	<b>14-35</b>	<b>14-97</b>
Number of contacts	18	19	37	4/8
Contact size	20	20	22 D	16/20
Voltage class	I	I	M	I

Image (contact arrangement)				
<b>Contact arrangement</b>	<b>16-6</b>	<b>16-8</b>	<b>16-26</b>	<b>16-35</b>
Number of contacts	6	8	26	55
Contact size	12	16	20	22 D
Voltage class	I	II	I	M

Contact arrangements in hermetically sealed design or with coaxial contacts upon request.

Ordering information inside front cover

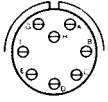
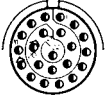
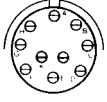
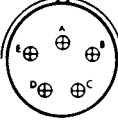
**Contact symbols:** 12 16 20 22D

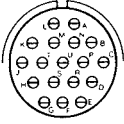
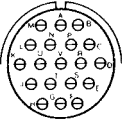
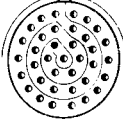
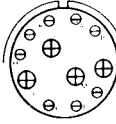
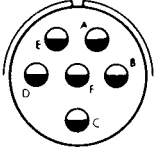
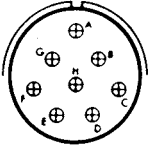
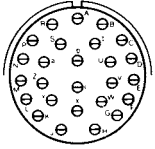
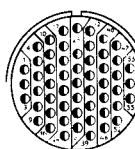
The following images show the front view of the pin insert and the back of the socket insert.

Image (contact arrangement)

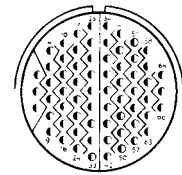
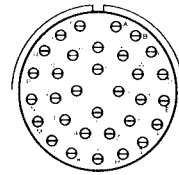
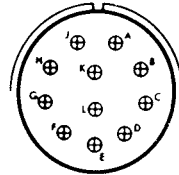
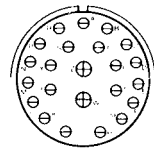

**Contact arrangement**

Number of contacts

Contact size

Voltage class

**16-99**

2/21

16/20

I

**18-11**

11

16

II

**18-32**

32

20

I

**18-35**

66

22 D

M

Image (contact arrangement)

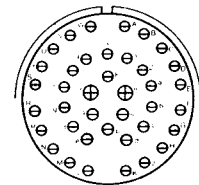
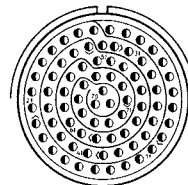
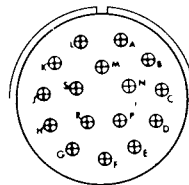
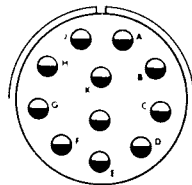

**Contact arrangement**

Number of contacts

Contact size

Voltage class

**20-11**

11

12

I

**20-16**

16

16

II

**20-35**

79

22 D

M

**20-39**

2/37

16/20

I

Image (contact arrangement)

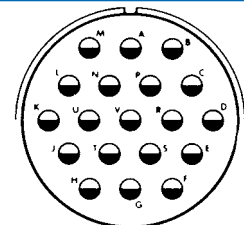
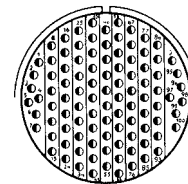
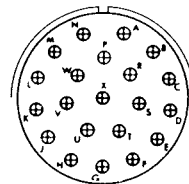
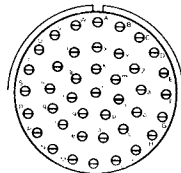

**Contact arrangement**

Number of contacts

Contact size

Voltage class

**20-41**

41

20

I

**22-21**

21

16

II

**22-35**

100

22 D

M

**24-19**

19

12

I

Image (contact arrangement)

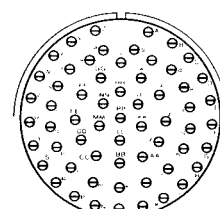
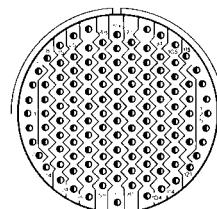
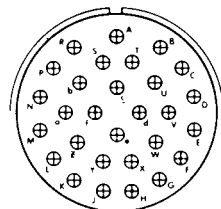

**Contact arrangement**

Number of contacts

Contact size

Voltage class

**24-29**

29

16

I

**24-35**

128

22 D

M

**24-61**

61

20

I

Contact arrangements in hermetically sealed design or with coaxial contacts upon request.

Ordering information inside front cover

Connector	Amphenol designation	VG designation (VG 96912)	PAN 6433-2
Receptacle with square flange	SJT 00 RT	A	B
	SJT 00 GS	–	–
	SJT 00 WW	–	–
	SJTP 00 RT	AA	–
Cable connecting plug	SJT 01 RT	–	–
Plug Plug (HF-sealed)	SJT 06 RT	E	F
	SJTG 06 RT	D	FG
Receptacle for single hole mounting	SJT 07 RT	B	A
	SJT 07 GS	–	–
	SJT 07 WW	–	–
	SJT 07 Y	–	–
Receptacle with solder flange	SJT IY	C	–
Backshell F	39013	F	–
Backshell SQ	42415	L	–
Strain release clamp	10-476808	G	–
Protective cap	For SJT 00	V1	A/B
	For SJT 06	V3	A/B
	For SJT 07	V2	A/B
Dummy	10-476807	W	–

The SJT series includes the following connectors with back-mounted removable crimp contacts.

These connectors are available as a moisture-proof version (service class RT), with a thread and anti-rotation teeth for attaching backshells (see p. 26 and 27).

### Design features

#### Shell

- Aluminum alloy
- Standard surface treatment: nickel-plated, cadmium-plated olive green chromate coating; conductive (see inside front cover)
- 100% contact protection (scoop-proof)
- Three pin bayonet coupling
- 5 guide grooves and lugs
- Coding from 5 angular positions of main guide groove
- 4 shell designs
- 9 shell sizes
- Grounding ring on plug SJTG 06 (360° HF-shielding)

#### Contact insert

- Plastic contact insert and contact retention system
- Fluorosilicone sealing elements on plug and wiring sides
- Lip seal on each pin contact
- Contact chamber identification on plug and wiring sides
- Numerous contact arrangements with 3 to 128 contacts

#### Crimp contacts

Pin and socket contacts made of high-quality copper alloy  
 Hard gold plated contact surface  
 Contact sizes 12 to 22D for cables AWG 12 to 28  
 Pin and socket contacts removable from back side



**SJT 00 RT**  
Receptacle with square flange



**SJT 01 RT**  
Cable connecting plug



**SJT 06 RT**  
Plug

**SJTG 06 RT**  
Plug (HF-sealed)



**SJT 07 RT**  
Receptacle for single hole mounting

## Receptacle with square flange SJT 00 RT

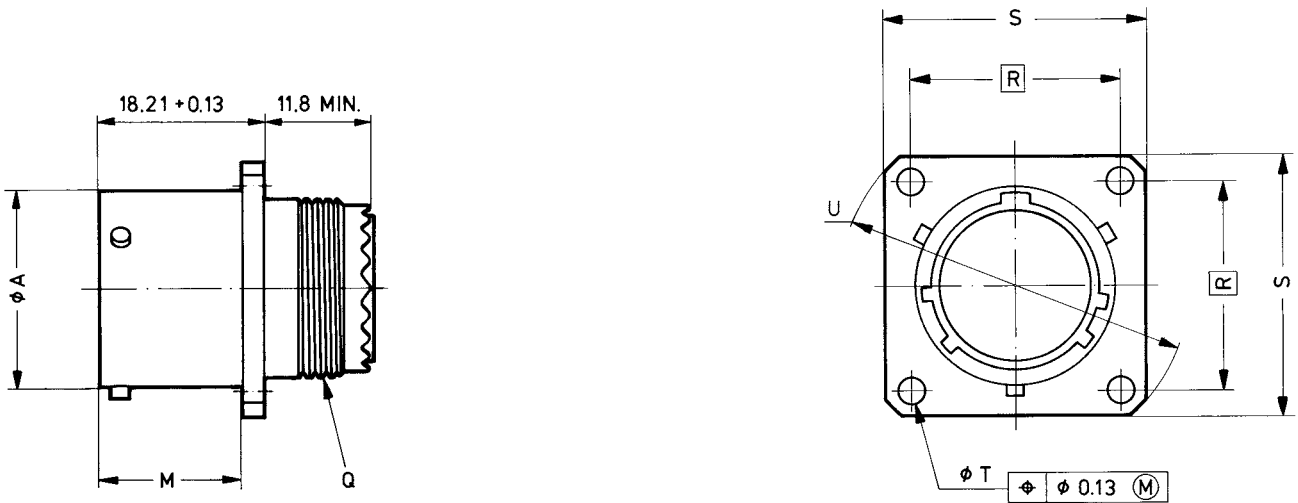

Ordering example: SJT 00 RT 14-35 P 014 See inside front cover

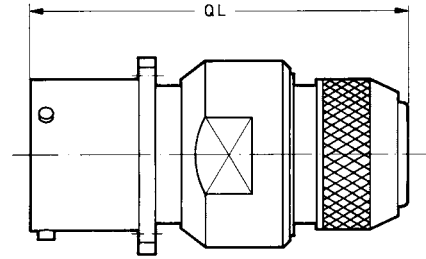
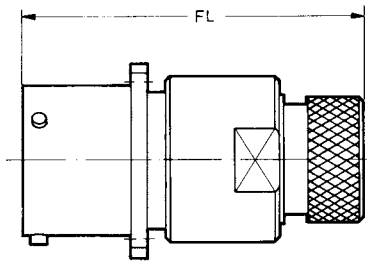

Receptacle with backshell F (see p. 26) Receptacle with backshell SQ (see p. 26)  
Backshells must be ordered separately.

Dimensions in mm

Shell size	Ø A + 0.03 - 0.13	FL max.	M 0 - 0.13	Thread Q Class 2 A UNEF	QL max.	$\overline{R}$ Theoret. dimensions	S ± 0.4	Ø T ± 0.13	U max.
8	12.01	52	16.05	0.4375-28	56	15.1	20.6	3.05	27.2
10	14.99	52	16.05	0.5625-24	57	18.3	23.8	3.05	32.0
12	19.05	52	16.05	0.6875-24	57	20.6	26.2	3.05	35.2
14	22.23	52	16.05	0.8125-20	57	23.0	28.6	3.05	38.4
16	25.40	52	16.05	0.9375-20	58	24.6	31.0	3.05	41.5
18	28.58	52	16.05	1.0625-18	58	27.0	33.3	3.05	44.7
20	31.75	52	15.29	1.1875-18	58	29.4	36.5	3.05	47.9
22	34.93	53	15.29	1.3125-18	58	31.8	39.7	3.05	51.1
24	38.10	54	15.29	1.4375-18	60	34.9	42.9	3.73	55.8

Assembly instructions p. 32 – 46.

## Cable connecting plug SJT 01 RT

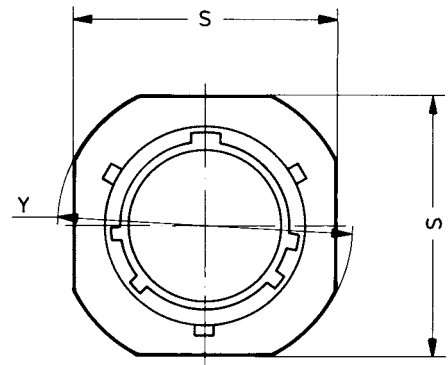
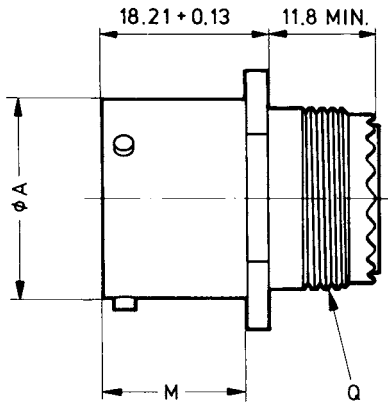

Ordering example: SJT 01 RT 14-35 P 014 See inside front cover

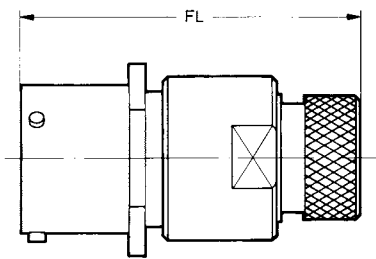

Cable connecting plug with backshell F (see p. 26)

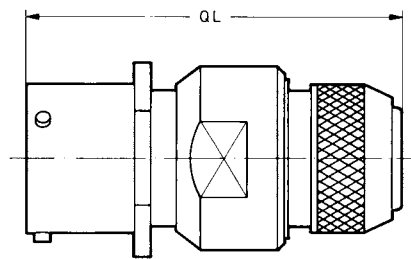

Cable connecting plug with backshell SQ (see p. 26)

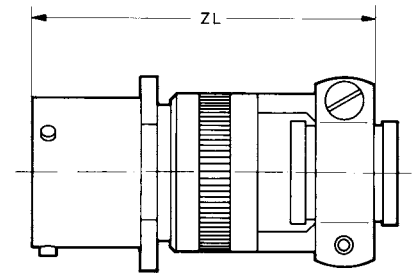

Cable connecting plug with strain release clamp (see p. 27)

Backshells and strain release clamp must be ordered separately.

## Dimensions in mm

Shell size	$\phi A$ + 0.03 - 0.13	FL max.	M 0 - 0.13	Thread Q Class 2 A UNEF	QL max.	S $\pm 0.4$	Y $\pm 0.4$	ZL max.
8	12.01	52	16.05	0.4375-28	56	20.6	23.8	48
10	14.99	52	16.05	0.5625-24	57	23.8	27.0	48
12	19.05	52	16.05	0.6875-24	57	26.2	29.3	48
14	22.23	52	16.05	0.8125-20	57	28.6	31.8	54
16	25.40	52	16.05	0.9375-20	58	31.0	34.1	54
18	28.58	52	16.05	1.0625-18	58	33.3	36.5	54
20	31.75	52	15.29	1.1875-18	58	36.5	39.7	57
22	34.93	53	15.29	1.3125-18	58	39.7	42.9	57
24	38.10	54	15.29	1.4375-18	60	42.9	46.0	59

## Plug SJT 06 RT

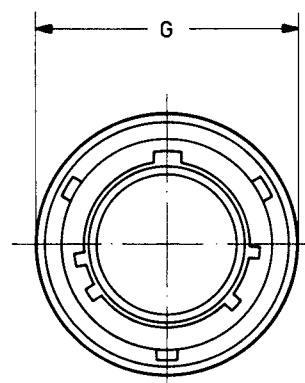
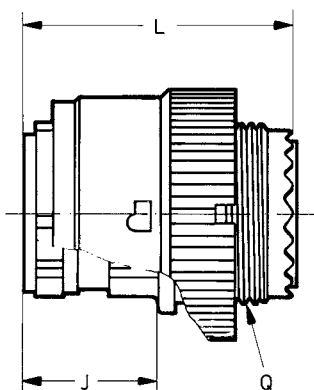

Ordering example: SJT 06 RT 14-35 S 014 See inside front cover

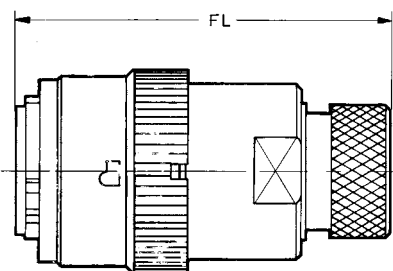

Plug with backshell F (see p. 26)

Backshell and strain relief clamp must be ordered separately.

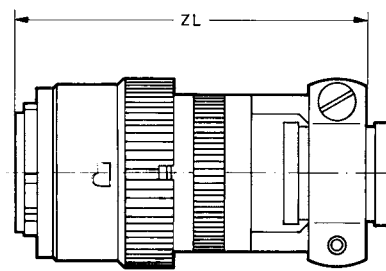

Plug with strain relief clamp (see p. 27)

### Dimensions in mm

Shell size	FL max.	G max.	J + 0.08 - 0.05	L max.	Thread Q Class 2 A UNEF	ZL max.
8	52	18.7	15.09	31	0.4375-28	48
10	52	21.5	15.09	31	0.5625-24	48
12	52	25.9	15.09	31	0.6875-24	48
14	52	29.0	15.09	31	0.8125-20	55
16	52	32.2	15.09	31	0.9375-20	55
18	52	35.4	15.09	31	1.0625-18	55
20	52	38.2	15.09	31	1.1875-18	58
22	53	41.3	15.09	31	1.3125-18	58
24	54	44.5	15.09	32	1.4375-18	59

## Plug SJTG 06 RT

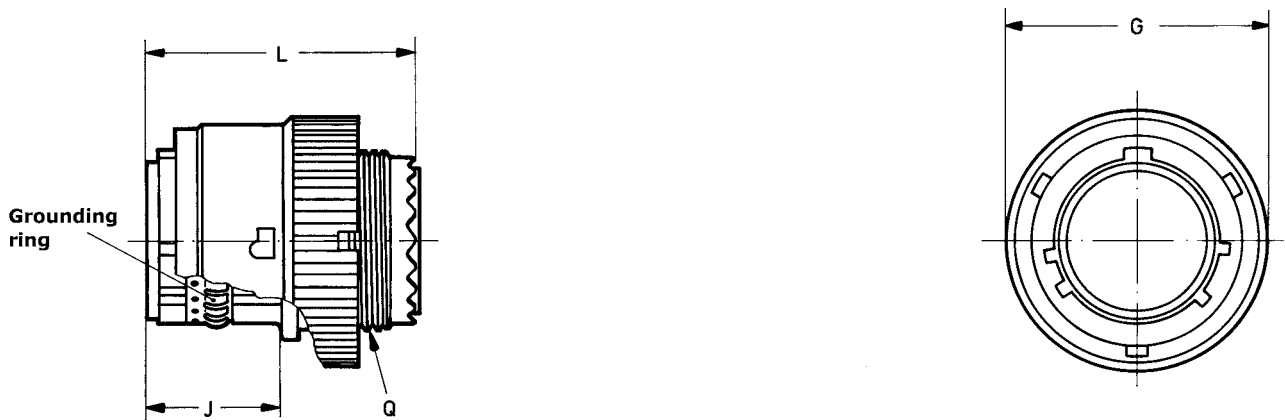

Ordering example: SJTG 06 RT 14-35 S 014 See inside front cover

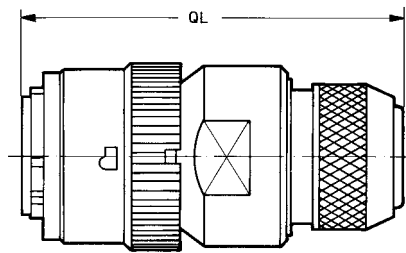

Plug with backshell SQ (see p. 26)  
Backshell must be ordered separately.

Dimensions in mm

Shell size	G max.	J + 0.08 - 0.05	L max.	Thread Q Class 2 A UNEF	QL max.
8	18.7	15.09	31	0.4375-28	56
10	21.5	15.09	31	0.5625-24	57
12	25.9	15.09	31	0.6875-24	57
14	29.0	15.09	31	0.8125-20	57
16	32.2	15.09	31	0.9375-20	58
18	35.4	15.09	31	1.0625-18	58
20	38.2	15.09	31	1.1875-18	58
22	41.3	15.09	31	1.3125-18	58
24	44.5	15.09	32	1.4375-18	59

Assembly instructions p. 32 – 46.

## Receptacle with single hole mounting SJT 07 RT

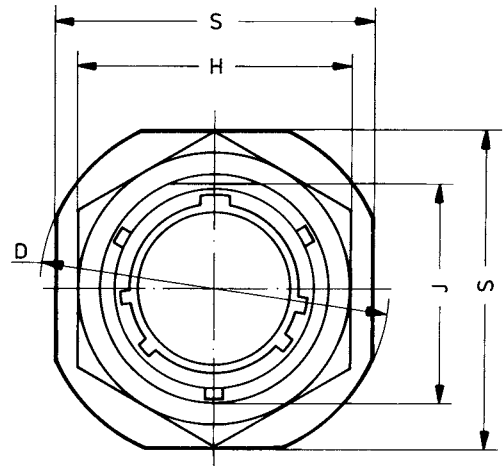
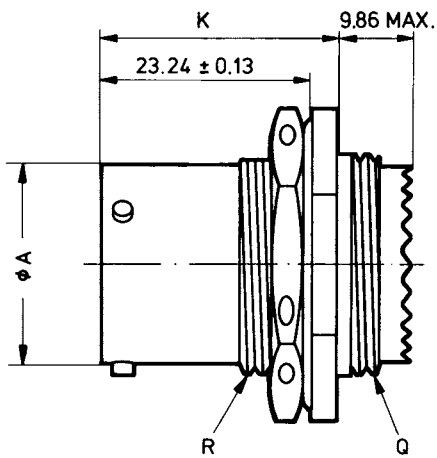

Ordering example: SJT 07 RT 14-35 P 014 See inside front cover

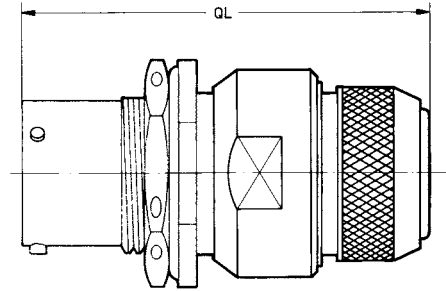
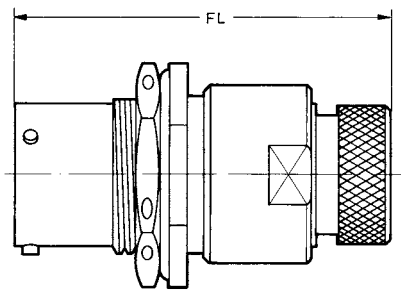

Receptacle with backshell F (see p. 26)

Receptacle with backshell SQ (see p. 26)

Backshells must be ordered separately.

### Dimensions in mm

Shell size	Ø A + 0.03 - 0.13	D max.	FL max.	H ± 0.4	J max.	K ± 0.2	Thread Q Class 2 A UNEF	QL max.	Thread R Class 2 A UNEF	S ± 0.3
8	12.01	27.3	57	19.1	13.46	26.0	0.5625-24	62	0.5625-24	23.8
10	14.99	30.5	57	22.2	16.64	26.0	0.6875-24	63	0.6875-24	27.0
12	19.05	35.3	57	27.0	20.78	26.0	0.8125-20	63	0.8750-20	31.8
14	22.23	38.4	57	30.2	23.93	26.0	0.9375-20	63	1.0000-20	34.9
16	25.40	41.6	57	33.3	27.08	26.0	1.0625-18	64	1.1250-18	38.1
18	28.58	44.8	58	36.5	30.25	26.8	1.1875-18	65	1.2500-18	41.3
20	31.75	49.6	58	39.7	33.43	26.8	1.3125-18	65	1.3750-18	46.0
22	34.93	52.7	59	42.9	36.60	26.8	1.4375-18	65	1.5000-18	49.2
24	38.10	55.9	59	46	39.78	26.8	1.4375-18	65	1.6250-18	52.4

In addition to removable crimp contacts, the SJT series includes hermetically sealed receptacles of the service class Y.

The hermetically sealed receptacles are only available with **non-removable pin contacts** and solder connection.

### Design features

- Steel shell, tin-plated.
- 9 shell sizes
- Contacts made of high-quality nickel alloy, tin-plated.
- Compression glass insert.
- Contacts are labeled on mating and termination face.

### Technical data

See p. 2 and 3.



#### SJT 07 Y

Hermetically sealed receptacle for single hole mounting



#### SJT IY

Hermetically sealed receptacle with solder flange

## Hermetically sealed receptacle for single hole mounting SJT 07 Y

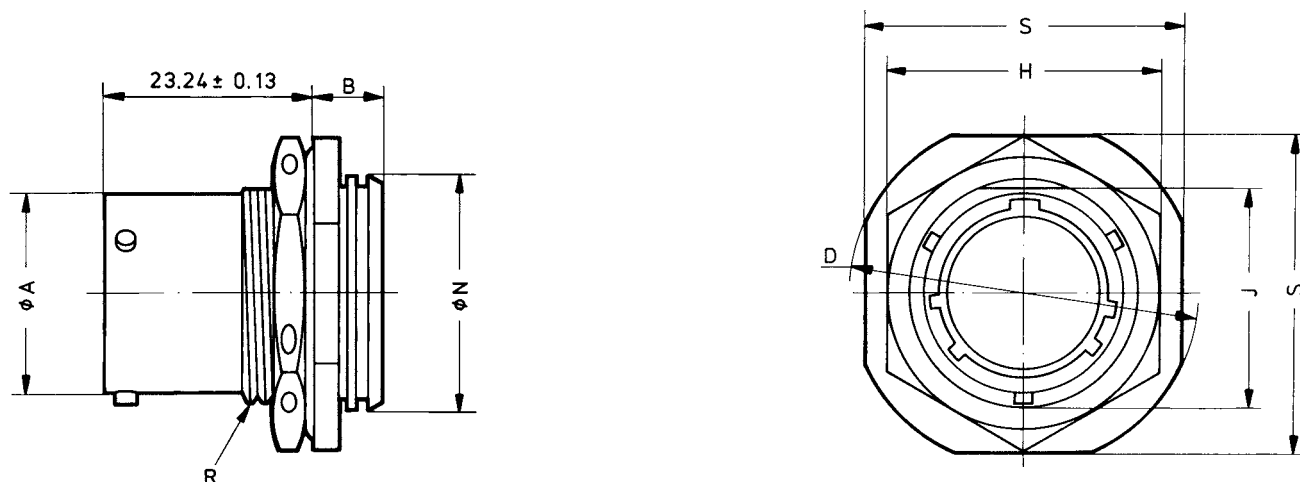

Ordering example: SJT 07 Y 14-19 P See inside front cover

### Dimensions in mm

Shell size	Ø A + 0.03 -0.13	B max.	D max.	H ± 0.4	J max.	Ø N + 0.28 0	Thread R Class 2 A UNEF	S ± 0.3
8	12.01	7.54	27.3	19.1	13.46	16.31	0.5625-24	23.8
10	14.99	7.54	30.5	22.2	16.64	19.46	0.6875-24	27.0
12	19.05	7.54	35.3	27.0	20.78	22.66	0.8750-20	31.8
14	22.23	7.54	38.4	30.2	23.93	25.86	1.0000-20	34.9
16	25.40	7.54	41.6	33.3	27.08	29.01	1.1250-18	38.1
18	28.58	8.33	44.8	36.5	30.25	32.21	1.2500-18	41.3
20	31.75	8.33	49.6	39.7	33.43	35.36	1.3750-18	46.0
22	34.93	8.33	52.7	42.9	36.60	38.56	1.5000-18	49.2
24	38.10	8.33	55.9	46.0	39.78	41.71	1.6250-18	52.4

## Receptacle with solder flange SJT IY

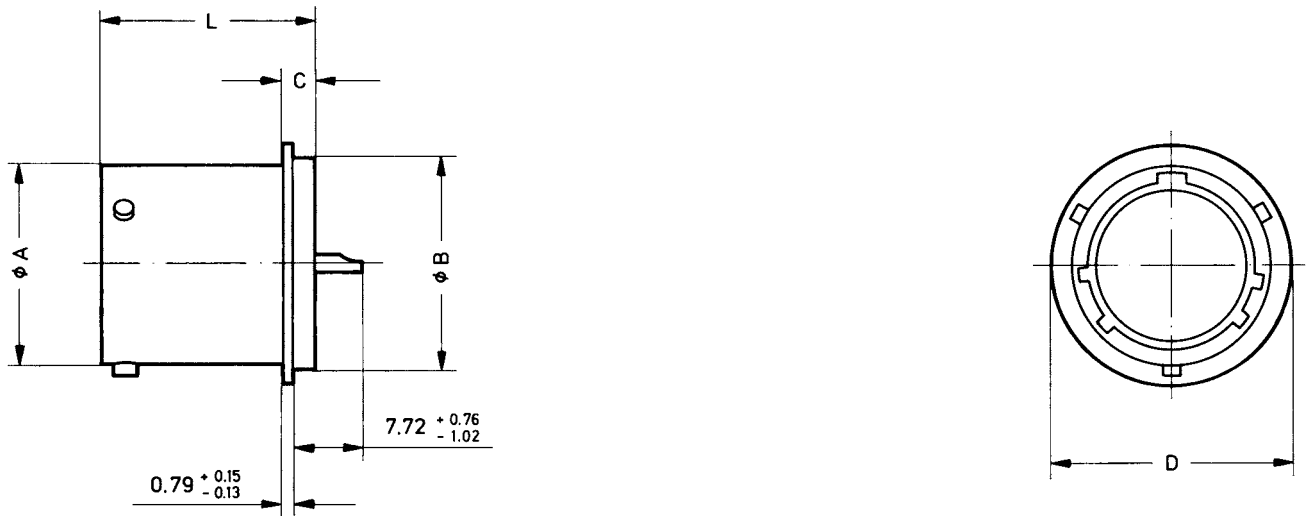

Ordering example: SJT IY 14-19 P See inside front cover

Dimensions in mm

Shell size	Ø A + 0.03 - 0.13	Ø B + 0.03 - 0.13	C + 0.15 - 0.13	Ø D + 0.28 - 0.25	L + 0.28 0
8	12.01	14.27	3.18	17.45	20.04
10	14.99	17.07	3.18	20.24	20.04
12	19.05	19.84	3.18	23.01	20.04
14	22.22	23.01	3.18	26.19	20.04
16	25.40	26.19	3.18	29.36	20.04
18	28.57	29.36	3.18	32.54	20.04
20	31.75	31.75	3.18	34.93	20.04
22	34.92	34.93	3.96	38.10	20.85
24	38.10	38.10	3.96	41.28	20.85

Assembly instructions p. 32 – 46.

**SJT GS**

PCB-connection

The receptacles SJT 00 GS and SJT 07 GS for printed circuit boards are identical to those of the service class RT (see p. 9 and inside front cover), with the exception of the contacts designed for soldering in rigid or flexible PCBs.

The pin and socket contacts are removable, and are delivered with the receptacle. To mount these contacts, use the same tools as for mounting crimp contacts (see p. 31). The necessary contact bore holes are shown on pages 39 to 46. The images show the front view of the pin insert in the normal position.

**SJT 00 GS**

Receptacle with PCB connection

**SJT 07 GS**

Receptacle with PCB connection

**SJT WW**

Wire-wrap connection

The receptacles SJT 00 WW and SJT 07 WW are identical to those of the service class RT (see p. 9 and inside front cover), with the exception of pin and socket contacts designed for wire-wrap connections, and are not removable.

The cross-section of the wire-wrap post is 0.6 x 0.6 mm, and corresponds to the specifications in DIN 41611, Sheet 2.

**SJT 00 WW**

Receptacle with wire-wrap connection

**SJT 07 WW**

Receptacle with wire-wrap connection

# SJT00AB / VG96912AB

## Flanschsteckdose

für Vorder- und Hinterwandmontage,  
Leiterplattenkontakte, montiert

## Flange-receptacle

for front- and rear panel mounting  
PCB-contacts, installed

Beispiel / example:

SJT00AB14-35PN029J

VG96912AB14-35PNJ

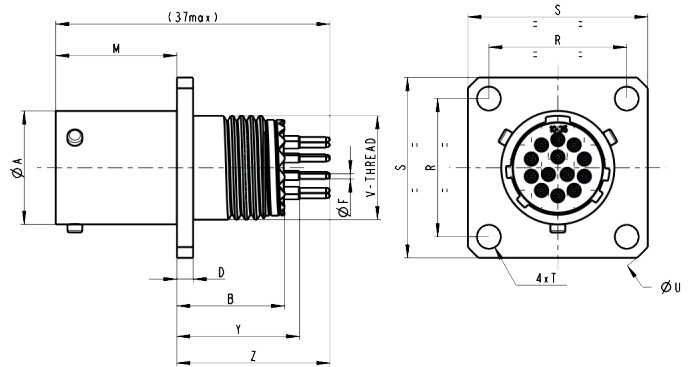

Gehäusegröße / Shell size	Ø A +0,03 -0,13	B min.	D ±0,25	M 0 -0,13	R	S ±0,4	Ø T ±0,13	V Gewinde/Thread UNEF-2A	U max.	Y max.	Z max.
8	12,01	14,30	2,16	16,05	15,10	20,60	3,05	0,4375-28	27,20	16,30	21,30
10	14,99	14,30	2,16	16,05	18,30	23,80	3,05	0,5625-24	32,00	16,30	21,30
12	19,05	14,30	2,16	16,05	20,60	26,20	3,05	0,6875-24	35,20	16,30	21,30
14	22,23	14,30	2,16	16,05	23,00	28,60	3,05	0,1825-20	38,40	16,30	21,30
16	25,40	14,30	2,16	16,05	24,60	31,00	3,05	0,9375-20	41,50	16,30	21,30
18	28,58	14,30	2,16	16,05	27,00	33,30	3,05	1,0625-18	44,70	16,30	21,30
20	31,75	15,00	2,92	15,29	29,40	36,50	3,05	1,1875-18	47,90	17,00	22,00
22	34,93	15,00	2,92	15,29	31,80	39,70	3,05	1,3125-18	57,10	17,00	22,00
24	38,10	15,00	2,92	15,29	34,90	42,90	3,73	1,4375-18	55,80	17,00	22,00

Kontaktgröße / Contact size	ØF ±0,5	VG96912	SJT
22D	0,60	✓	✓
20	0,80	✓	✓
16	1,15	✗	✓
12	1,70	✗	✓

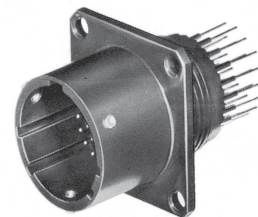

## SJT07BA / VG96912BA

### Einloch-Steckdose

für Hinterwandmontage,  
Leiterplattenkontakte, montiert

### Jam-Nut-Receptacle

for rear panel mounting  
PCB-contacts, installed

Beispiel / example:

SJT07BA14-35PN029J

VG96912BA14-35PNJ

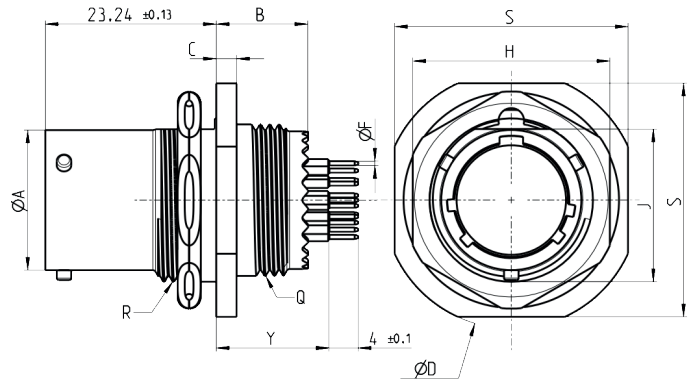

Gehäusegröße / Shell size	ØA +0,03 -0,13	B ±0,1	C ±0,1	ØD max.	H ±0,4	J max.	R Gewinde/Thread UNEF-2A	S ±0,3	Q Gewinde/Thread UNEF-2A	Y ±0,5
8	12,01	12,50	2,76	27,30	19,10	13,46	0,5625-24	23,80	0,5625-24	15,45
10	14,99	12,50	2,76	30,50	22,20	16,64	0,6875-24	27,00	0,6875-24	15,45
12	19,05	12,50	2,76	35,30	27,00	20,78	0,8750-20	31,80	0,8125-20	15,45
14	22,23	12,50	2,76	38,40	30,20	23,93	1,0000-20	34,90	0,9375-20	15,45
16	25,40	12,50	2,76	41,60	33,30	27,08	1,1250-18	38,10	1,0625-18	15,45
18	28,58	13,30	3,56	44,80	36,50	30,25	1,2500-18	41,30	1,1875-18	15,45
20	31,75	13,30	3,56	49,60	39,70	33,43	1,3750-18	46,00	1,3125-18	15,45
22	34,93	13,30	3,56	52,70	42,90	36,60	1,5000-18	49,20	1,4375-18	15,45
24	38,10	13,30	3,56	55,90	46,00	39,78	1,6250-18	52,40	1,4375-18	15,45

Kontaktgröße / Contact size	ØF ±0,5	VG96912	SJT
22D	0,70	✓	✓
20	0,70	✓	✓



## Receptacle with square flange SJT 00 GS

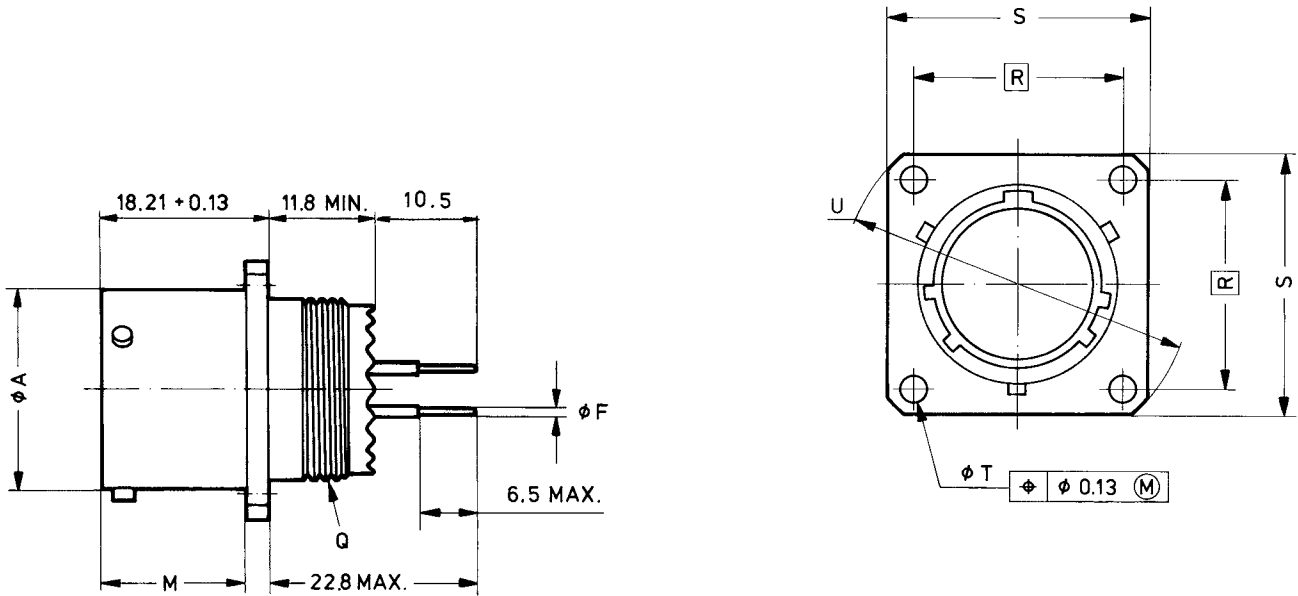

Ordering example: SJT 00 RT 14-35 P 014 See inside front cover

Position of contact bore holes p. 39 to 46.

Dimensions in mm

Shell size	Ø A + 0.03 - 0.13	M 0 - 0.13	Thread Q Class 2 A UNEF	$\boxed{R}$ Theoret. dimensions	S ± 0.4	Ø T ± 0.13	U max.	Contact size	Ø F ± 0.05
8	12.01	16.05	0.4375-28	15.1	20.6	3.05	27.2	22 D	0.6
10	14.99	16.05	0.5625-24	18.3	23.8	3.05	32.0	20	0.8
12	19.05	16.05	0.6875-24	20.6	26.2	3.05	35.2		
14	22.23	16.05	0.8125-20	23.0	28.6	3.05	38.4		
16	25.40	16.05	0.9375-20	24.6	31.0	3.05	41.5		
18	28.58	16.05	1.0625-18	27.0	33.3	3.05	44.7		
20	31.75	15.29	1.1875-18	29.4	36.5	3.05	47.9		
22	34.93	15.29	1.3125-18	31.8	39.7	3.05	57.1		
24	38.10	15.29	1.4375-18	34.9	42.9	3.735	55.8		

Assembly instructions p. 32 – 46.

## Receptacle with single hole mounting SJT 07 GS

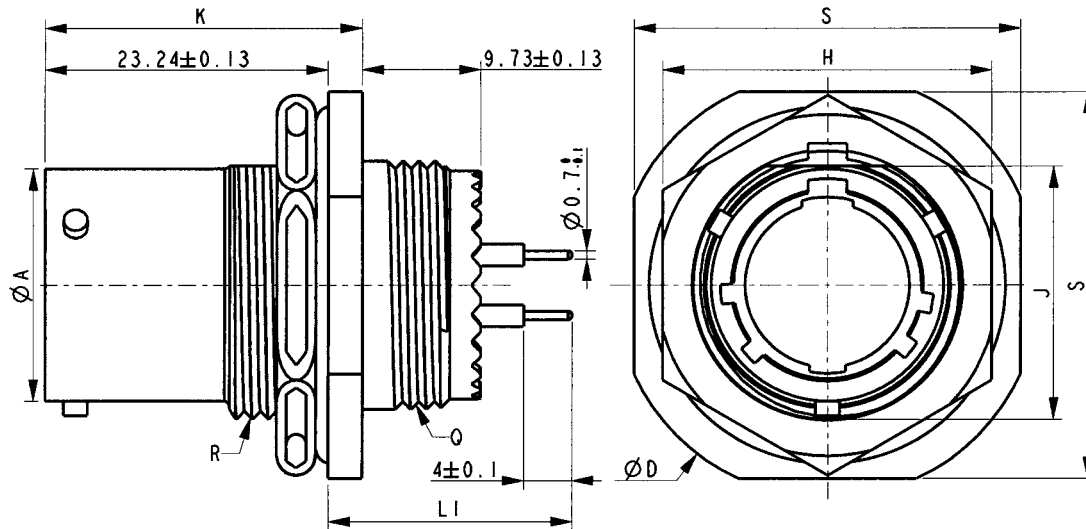

Ordering example: SJT 07 GS 14-35 S 014 See inside front cover

Position of contact bore holes p. 39 to 46.

### Dimensions in mm

Shell size	Ø A	D	H	J	K	Thread Q	Thread R	S	Contact type	LI
	+ 0.03 -0.13	max.	± 0.4	max.	± 0.2	Class 2 A UNEF	Class 2 A UNEF	± 0.3		
8	12.01	27.3	19.1	13.46	26.0	0.5625-24	0.5625-24	23.8	Pin	19.50 ± 0.51
10	14.99	30.5	22.2	16.64	26.0	0.6875-24	0.6875-24	27.0	Socket	19.38 ± 0.57
12	19.05	35.3	27.0	20.78	26.0	0.8125-20	0.8750-20	31.8		
14	22.23	38.4	30.2	23.93	26.0	0.9375-20	1.0000-20	34.9		
16	25.40	41.6	33.3	27.08	26.0	1.0625-18	1.1250-18	38.1		
18	28.58	44.8	36.5	30.25	26.8	1.1875-18	1.2500-18	41.3		
20	31.75	49.6	39.7	33.43	26.8	1.3125-18	1.3750-18	46.0		
22	34.93	52.7	42.9	36.60	26.8	1.4375-18	1.5000-18	49.2		
24	38.10	55.9	46.0	39.78	26.8	1.4375-18	1.6250-18	52.4		

Assembly instructions p. 32 – 46.

## Receptacle with square flange SJT 00 WW

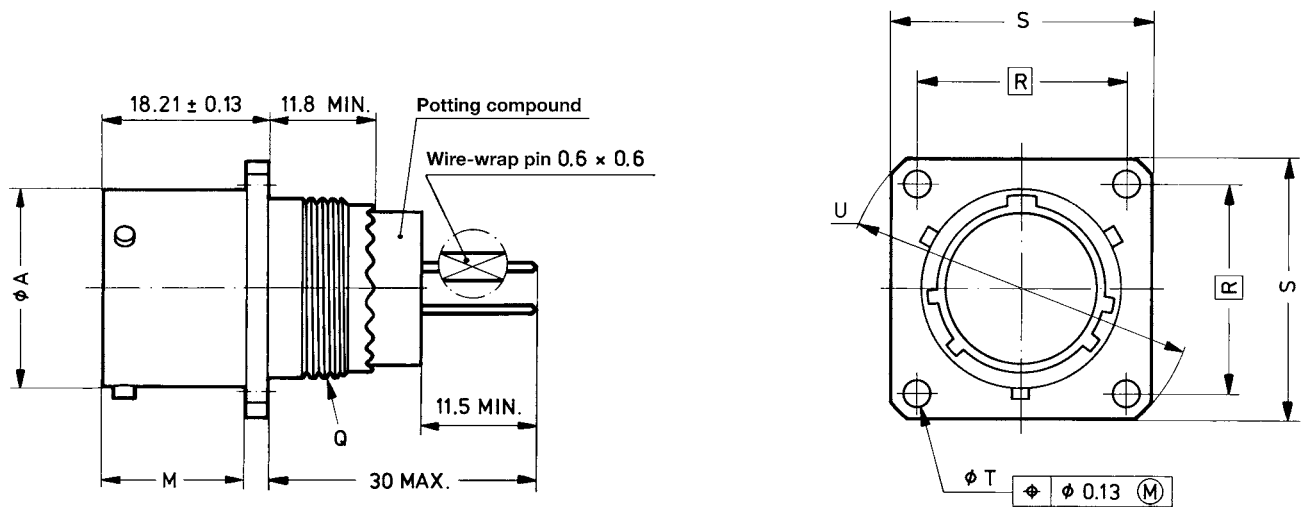

Ordering example: SJT 00 WW 14-35 S 014 See inside front cover

### Dimensions in mm

Shell size	Ø A + 0.03 - 0.13	M 0 - 0.13	Thread Q Class 2 A UNEF	R Theoret. Dimensions	S ± 0.4	ø T ± 0.13	U max.
8	12.01	16.05	0.4375-28	15.1	20.6	3.05	27.2
10	14.99	16.05	0.5625-24	18.3	23.8	3.05	32.0
12	19.05	16.05	0.6875-24	20.6	26.2	3.05	35.2
14	22.23	16.05	0.8125-20	23.0	28.6	3.05	38.4
16	25.40	16.05	0.9375-20	24.6	31.0	3.05	41.5
18	28.58	16.05	1.0625-18	27.0	33.3	3.05	44.7
20	31.75	15.29	1.1875-18	29.4	36.5	3.05	47.9
22	34.93	15.29	1.3125-18	31.8	39.7	3.05	51.1
24	38.10	15.29	1.4375-18	34.9	42.9	3.73	55.8

## Receptacle for single hole mounting SJT 07 WW

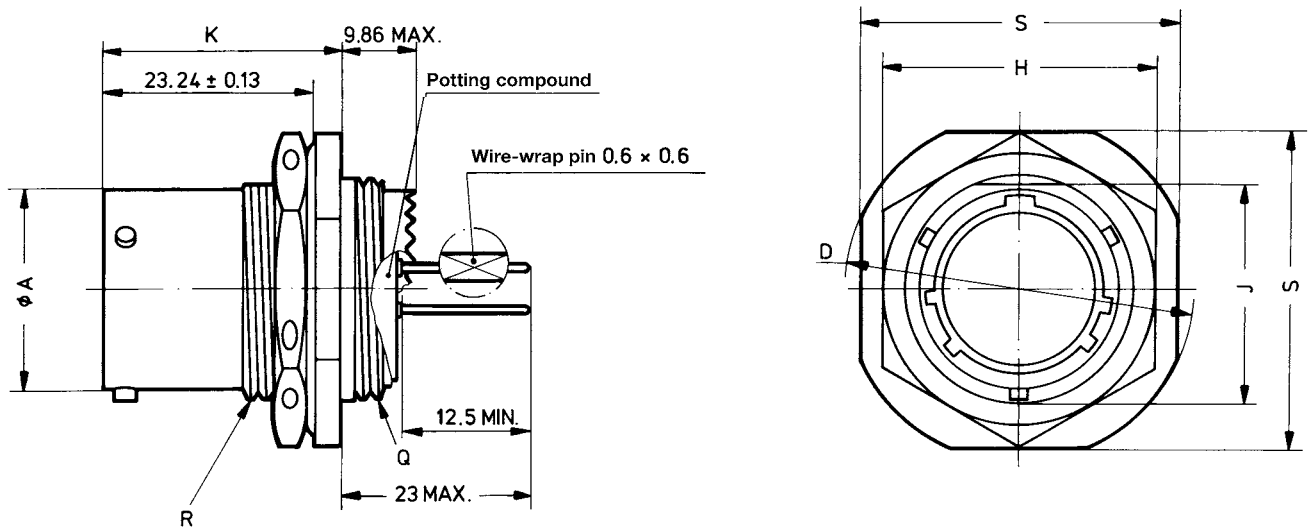

Ordering example: SJT 01 RT 14-35 P 014 See inside front cover

### Dimensions in mm

Shell size	Ø A + 0.03 -0.13	D max.	H ± 0.4	J max.	K ± 0.2	Thread Q Class 2 A UNEF	Thread R Class 2 A UNEF	S ± 0.3
8	12.01	27.3	19.1	13.46	26.0	0.5625-24	0.5625-24	23.8
10	14.99	30.5	22.2	16.64	26.0	0.6875-24	0.6875-24	27.0
12	19.05	35.3	27.0	20.78	26.0	0.8125-20	0.8750-20	31.8
14	22.23	38.4	30.2	23.93	26.0	0.9375-20	1.0000-20	34.9
16	25.40	41.6	33.3	27.08	26.0	1.0625-18	1.1250-18	38.1
18	28.58	44.8	36.5	30.25	26.8	1.1875-18	1.2500-18	41.3
20	31.75	49.6	39.7	33.43	26.8	1.3125-18	1.3750-18	46.0
22	34.93	52.7	42.9	36.60	26.8	1.4375-18	1.5000-18	49.2
24	38.10	55.9	46.0	39.78	26.8	1.4375-18	1.6250-18	52.4

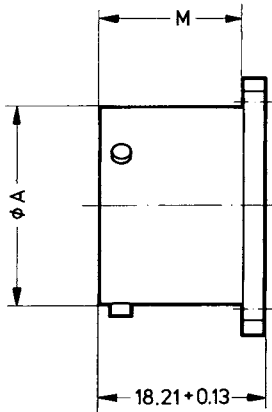

**Dummy  
10-476807**

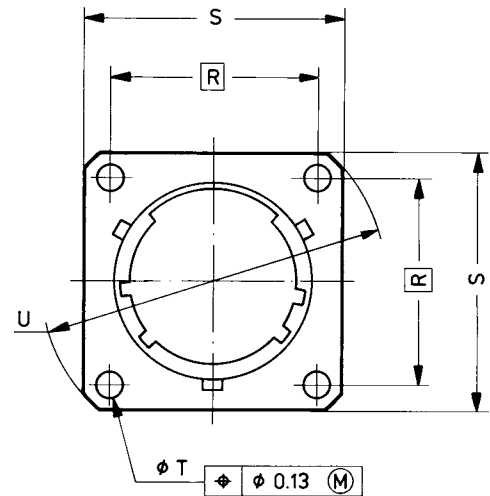

Dimensions in mm

Shell size	Order number	Ø A + 0.03 - 0.13	M 0 - 0.13	R Theoret. Dimensions	S ± 0.4	Ø T ± 0.13	U max.
8	10-476807-89	12.01	16.05	15.1	20.6	3.05	27.2
10	10-476807-109	14.99	16.05	18.3	23.8	3.05	32.0
12	10-476807-129	19.05	16.05	20.6	26.2	3.05	35.2
14	10-476807-149	22.23	16.05	23.0	28.6	3.05	38.4
16	10-476807-169	25.40	16.05	24.6	31.0	3.05	41.5
18	10-476807-189	28.58	16.05	27.0	33.3	3.05	44.7
20	10-476807-209	31.75	15.29	29.4	36.5	3.05	47.9
22	10-476807-229	34.93	15.29	31.8	39.7	3.05	51.1
24	10-476807-249	38.10	15.29	34.9	42.9	3.73	55.8

## Crimp contacts



Contact size	Order number	
	Pin contact	Socket contact
22D	39587-003	39628-003
	M39029/58-360	M39029/56-348
20	39585-003	39625-003
	M39029/58-363	M39029/56-351
16	39583-003	39622-003
	M39029/58-364	M39029/56-352
12	39581-003	39619-003
	M39029/58-365	M39029/56-353

## GS dip solder contacts (for printed circuit boards)



Contact size	Design	Order number	
		Pin contact	Socket contact
22D	00	39833-003	39835-003
	07	50075-003	50076-003
20	00	46279-003	46282-003
	07	50077-003	50078-003

Contact sizes 12 and 16 upon request

## Sealing plug



Contact size	Color code	Order number
22D	black	10-405996-221
		MS 27488-221
20	red	10-405996-201
		MS 27488-201
16	blue	10-405996-161
		MS 27488-161
12	yellow	10-405996-121
		MS 27488-121

# VG96940-6 & VG95328-7

**Flanschdichtung**  
für Vorder- und  
Hinterwandmontage

**Flange gaskets**  
for front- and rear panel mounting

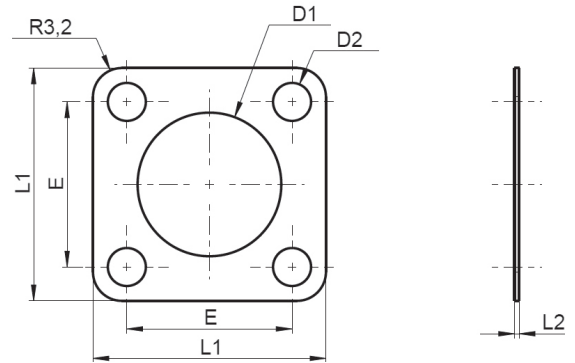
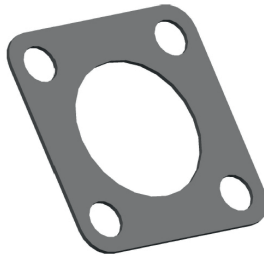

Größe / Size	VG96940-6 Version A	D1 +0,4	D2 +0,3	L1 ±0,25	L2 ±0,15	E ±0,25	VG95328T07 Version A	D1 +1	D2 ±0,3	L1 max.	L2 +0,5	E ±0,3
8	VG96940-06C011A	12,70	3,5	22,40	0,81	15,09	VG95328T07A8	12,70	3,3	22,7	0,5	15,1
10	VG96940-06C012A	15,88	3,5	25,50	0,81	18,26	VG95328T07A10	15,9	3,3	25,8	0,5	18,3
12	VG96940-06C013A	19,05	3,5	27,90	0,81	20,65	VG95328T07A12	19,0	3,3	28,2	0,5	20,6
14	VG96940-06C014A	22,23	3,5	30,30	0,81	23,01	VG95328T07A14	22,2	3,3	30,6	0,5	23,0
16	VG96940-06C015A	25,40	3,5	32,70	0,81	24,61	VG95328T07A16	25,4	3,3	33,0	0,5	24,6
18	VG96940-06C016A	28,58	3,5	35,10	0,81	27,00	VG95328T07A18	28,6	3,3	35,4	0,5	27,0
20	VG96940-06C017A	31,75	3,5	38,20	0,81	29,36	VG95328T07A20	31,7	3,3	38,5	0,5	29,4
22	VG96940-06C018A	34,93	3,5	41,40	0,81	31,75	VG95328T07A22	34,9	3,3	41,7	0,5	31,8
24	VG96940-06C019A	38,10	4,5	44,60	0,81	34,93	VG95328T07A24	38,1	4,0	44,9	0,5	34,9

Technische Eigenschaften / Technical specifications:	VG96940-6 Version A	VG95328-7 Version A
Material:	Fluorsilikon gefüllt mit Ag/Al Partikeln Fluor silicone with Ag/Al conductive filler	Elastomer
Shore Härte gemäß / Shore hardness acc. to	65 ± 10 (Shore A) DIN EN ISO 868	60 + 10 (Shore A) DIN EN 53505
Farbe / Color	hell grün / light green	dunkelgrau / schwarz dark gray / black
Temperatureinsatzbereich / Operating temperature range	-55°C bis / to +160°C	-55°C bis / to +125°C
Abschirmeeigenschaften / Shielding effectiveness:	≥ 80 dB.	* nicht leitfähig / non conductive

## VG96940-6 G / AALB-FSPL-06 G

### Dichtung für Einlochsteckdosen

Diese Dichtung wird bei der Montage zusätzlich eingelegt

### Gasket for jam nut receptacles

This gasket will be additionally inserted during the assembly

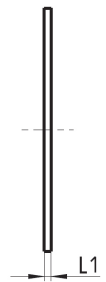
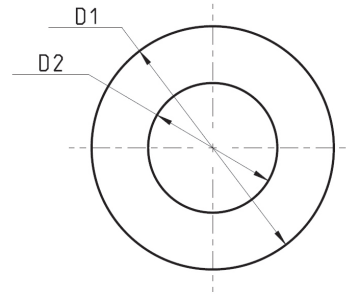
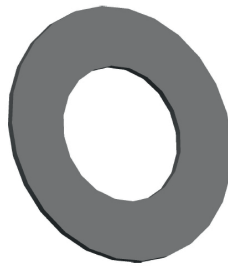

VG-Nummer / VG number	Größe / Size	D1 max.	D2 Richtwert / Standard value	L1 Richtwert / Standard value
VG96940-06G001A	8	27,2	14,5	0,5 bis 0,8
VG96940-06G002A	10	30,5	17,7	
VG96940-06G004A	12	35,2	22,5	
VG96940-06G005A	14	38,4	25,6	
VG96940-06G006A	16	41,6	28,8	
VG96940-06G007A	18	44,8	32,2	
VG96940-06G008A	20	49,5	35,2	
VG96940-06G009A	22	52,7	38,3	
VG96940-06G010A	24	55,9	41,5	

Technische Eigenschaften / Technical specifications:	VG96940-6 Version A
Material:	Fluorsilikon gefüllt mit Ag/Al Partikeln Fluor silicone with Ag/Al conductive filler
Shore Härte gemäß / Shore hardness acc. to	65 ± 10 (Shore A) DIN EN ISO 868
Farbe / Color	hell grün / light green
Temperatureinsatzbereich / Operating temperature range	-55°C bis / to +160°C
Abschirmeigenschaften / Shielding effectiveness:	≥ 80 dB.

# BS1SRM

**Zugentlastung**

Kabelklemme,  
ohne Tülle

**Strain relief**

cable clamp,  
without bushing

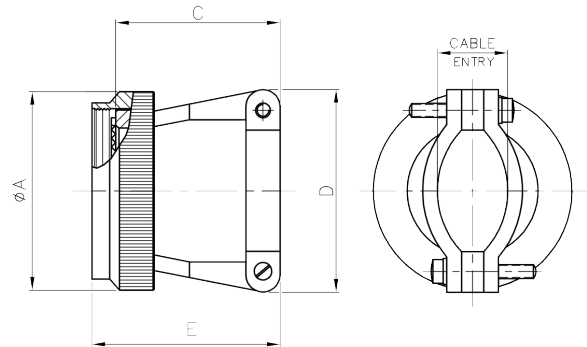

Beispiel / example:  
BS1SRM08999XA

Gehäuse-Größe   Bauform Shell size   Shell style		Teilenummer / Dash Number	A max.	C max.	D max.	E max.	Kabelausgang / Cabel Entry	
Einlochst.dose Jam nut rec.	Alle Anderen All others						min.	max.
-	8	08	19,05	23,11	21,59	27,94	2,49	5,94
8	10	10	22,60	23,11	22,86	27,94	3,89	5,94
10	12	12	25,65	25,65	27,94	30,48	4,83	8,33
12	14	14	29,92	26,92	29,21	31,75	6,60	11,61
14	16	16	33,02	29,46	33,02	34,44	7,19	15,60
16	18	18	35,56	35,81	38,10	40,64	8,26	16,10
18	20	20	38,86	38,35	40,64	43,21	8,71	17,73
20	22	22	41,91	42,16	43,18	46,99	9,68	20,90
22 / 24	24	24	44,45	44,70	45,72	49,56	10,62	21,67

## 50774 / AA96912F1 / VG96912F1

**Formteiladapter**

für die Verwendung eines  
wärmeschrumpfenden Formteils

**Shrink boot adapter**

for use with a heat shrink boot

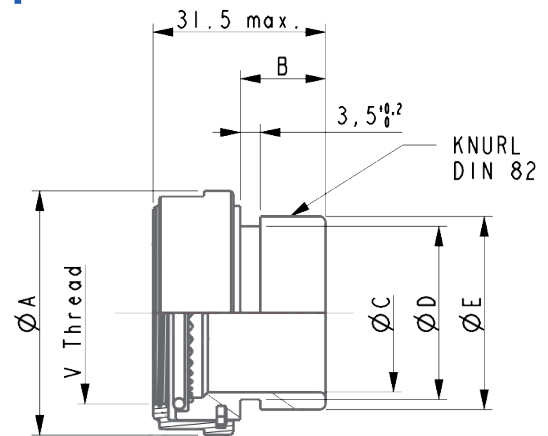

Beispiel / example:

50774-005-029J

VG96912F1-16J

AA96912F1-16

Ergänzende Komponenten /  
Complementary components:

Formteile / Heat shrink boot: VG95343

Gehäuse-Größe   Bauform Shell size   Shell style		Teilenummer / Dash-number		ØA ±0,2	V Gewinde / Thread UNEF-2B	B 0 -0,3	ØC +0,2 0	ØD 0 -0,2	ØE ±0,2	SW 0 -0,2
Einlochstdose Jam nut rec.	Alle Anderen All others	VG	SJT							
-	8	8	1	19	7/16 - 28	12,5	8,56	12,0	14	17
8	10	10	2	22	9/16 - 24	12,5	12,0	14,0	16	20
10	12	12	3	25	11/16 - 24	12,5	13,8	16,0	18	23
12	14	14	4	28	13/16 - 20	12,5	16,8	20,0	22	26
14	16	16	5	30	15/16 - 20	12,5	19,8	23,0	25	28
16	18	18	6	34	1 1/16 - 18	12,5	22,8	24,5	28	32
18	20	20	7	38	1 3/16 - 18	15,0	26,0	28,5	32	36
20	22	22	8	43	1 5/16 - 18	15,0	27,9	30,5	34	41
22 / 24	24	24	9	45	1 7/16 - 18	15,0	31,9	34,5	38	43

# 42415 / AA96912L / VG96912L

### Klemmkonus

für den Anschluss eines Schirmgeflechts, sowie für die Verwendung eines wärmeschrumpfenden Formteils

### Clamping cone

for braid termination and for use with a heat shrink boot

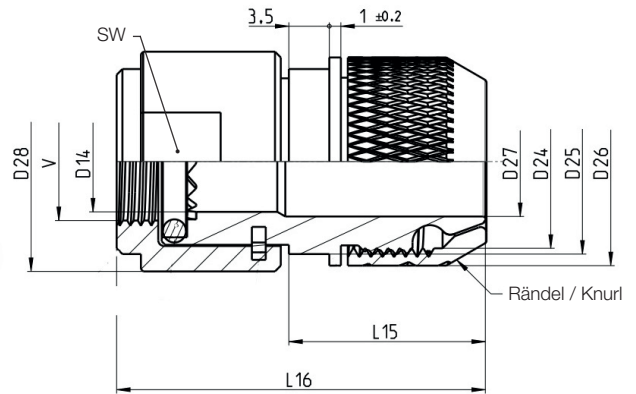

Beispiel / example:  
 42415-064-016-029J  
 VG96912L016J  
 AA96912L016

Ergänzende Komponenten /  
 Complementary components:

Formteile / Heat shrink boot: VG95343

Gehäuse-Größe   Bauform Shell size   Shell style		Teilenummer / Dash-number		ØD14 max.	D24 Gewinde / Thread	ØD25 0 -0,2	ØD26 +0,5 0	ØD27 +0,2 0	ØD28 ±0,2	L15 0 -0,7	L16 max.	V Gewinde / Thread UNE-F-2B	SW
Einlochst.dose Jam nut rec.	Alle Anderen All others	VG	SJT										
-	8	8	1	8,7	M12x1	12,0	14,0	6,2	19,0	16,2	34,0	7/16 - 28	17
		001	1-001	8,7	M16x1	16,0	18,0	9,5	19,0	17,2	35,0	7/16 - 28	17
8	10	10	2	11,5	M14x1	14,0	16,0	7,0	22,0	17,2	35,0	9/16 - 24	20
		002	2-002	11,5	M12x1	12,0	14,0	6,2	22,0	16,2	34,0	9/16 - 24	20
		003	2-003	11,5	M16x1	16,0	18,0	9,5	22,0	17,2	35,0	9/16 - 24	20
		004	2-004	11,5	M20x1	20,0	22,0	12,5	22,0	18,2	35,0	9/16 - 24	20
		005	2-005	11,5	M23x1	23,0	25,0	15,5	22,0	18,2	36,0	9/16 - 24	20
		006	2-006	11,5	M26x1	24,5	28,0	18,5	22,0	18,2	38,0	9/16 - 24	20
10	12	12	3	14,6	M16x1	16,0	18,0	9,5	25,0	18,2	36,0	11/16 - 24	23
		007	3-007	14,6	M12x1	12,0	14,0	6,2	25,0	16,2	35,0	11/16 - 24	23
		008	3-008	14,6	M14x1	14,0	16,0	7,0	25,0	17,2	35,0	11/16 - 24	23
		009	3-009	14,6	M20x1	20,0	22,0	12,5	25,0	18,2	35,0	11/16 - 24	23
		010	3-010	14,6	M23x1	23,0	25,0	15,5	25,0	18,2	36,0	11/16 - 24	23
		011	3-011	14,6	M26x1	24,5	28,0	18,5	25,0	18,2	38,0	11/16 - 24	23
12	14	14	4	17,6	M20x1	20,0	22,0	12,5	28,0	18,2	36,0	13/16 - 20	26
		012	4-012	17,6	M12x1	12,0	14,0	6,2	28,0	16,2	34,0	13/16 - 20	26
		013	4-013	17,6	M14x1	14,0	16,0	7,0	28,0	17,2	35,0	13/16 - 20	26
		014	4-014	17,6	M16x1	16,0	18,0	9,5	28,0	17,2	35,0	13/16 - 20	26
		015	4-015	17,6	M23x1	23,0	25,0	15,5	28,0	18,2	35,0	13/16 - 20	26
		016	4-016	17,6	M26x1	24,5	28,0	18,5	28,0	18,2	36,0	13/16 - 20	26
14	16	16	5	20,6	M23x1	23,0	25,0	15,5	30,0	18,2	36,0	15/16 - 20	28
		017	5-017	20,6	M14x1	14,0	16,0	7,0	31,0	17,2	36,0	15/16 - 20	29
		018	5-018	20,6	M16x1	16,0	18,0	9,5	31,0	17,2	36,0	15/16 - 20	29
		019	5-019	20,6	M20x1	20,0	22,0	12,5	31,0	18,2	36,0	15/16 - 20	29
		020	5-020	20,6	M26x1	24,5	28,0	18,5	31,0	18,2	36,0	15/16 - 20	29
		021	5-021	20,6	M30x1	28,5	32,0	21,5	31,0	18,2	36,0	15/16 - 20	29
022	5-022	20,6	M32x1	30,5	34,0	23,5	31,0	18,2	36,0	15/16 - 20	29		

## 42415 / AA96912L / VG96912L

**Klemmkonus**

für den Anschluss eines Schirmgeflechts, sowie für die Verwendung eines wärmeschrumpfenden Formteils

**Clamping cone**

for braid termination and for use with a heat shrink boot

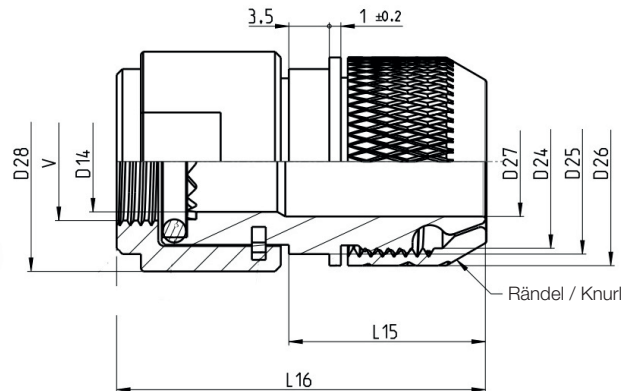

Beispiel / example:

42415-064-016-029J

VG96912L016J

AA96912L016

Ergänzende Komponenten /  
Complementary components:

Formteile / Heat shrink boot: VG95343

Gehäuse-Größe   Bauform Shell size   Shell style		Teilenummer / Dash-number		ØD14 max.	D24 Gewinde / Thread	ØD25 0 -0,2	ØD26 +0,5 0	ØD27 +0,2 0	ØD28 ±0,2	L15 0 -0,7	L16 max.	V Gewinde / Thread UNEF-2B	SW
Einlochst.dose Jam nut rec.	Alle Anderen All others	VG	SJT										
16	18	18	6	23,5	M26x1	24,5	28,0	18,5	34,0	18,2	36	1 1/16 - 18	32
		023	6-023	23,5	M16x1	16,0	18,0	9,5	34,0	17,2	36	1 1/16 - 18	32
		024	6-024	23,5	M20x1	20,0	22,0	12,5	34,0	18,2	36	1 1/16 - 18	32
		025	6-025	23,5	M23x1	23,0	25,0	15,5	34,0	18,2	36	1 1/16 - 18	32
		026	6-026	23,5	M30x1	28,5	32,0	21,5	34,0	18,2	36	1 1/16 - 18	32
		027	6-027	23,5	M32x1	30,5	34,0	23,5	34,0	18,2	36	1 1/16 - 18	32
		028	6-028	23,5	M36x1	34,5	38,0	27,5	34,0	18,2	36	1 1/16 - 18	32
18	20	20	7	26,5	M30x1	28,5	32,0	21,5	38,0	18,2	36	1 3/16 - 18	36
		029	7-029	26,5	M16x1	16,0	18,0	9,5	38,0	17,2	36	1 3/16 - 18	36
		030	7-030	26,5	M20x1	20,0	22,0	12,5	38,0	18,2	36,5	1 3/16 - 18	36
		031	7-031	26,5	M23x1	23,0	25,0	15,5	38,0	18,2	36,5	1 3/16 - 18	36
		032	7-032	26,5	M16x1	24,5	28,0	18,5	38,0	18,2	36	1 3/16 - 18	36
		033	7-033	26,5	M32x1	30,5	34,0	23,5	38,0	18,2	36	1 3/16 - 18	36
		034	7-034	26,5	M36x1	34,5	38,0	27,5	38,0	18,2	36	1 3/16 - 18	36
20	22	22	8	30,1	M32x1	30,5	34,0	23,5	43,0	18,2	36	1 5/16 - 18	41
		035	8-035	30,1	M16x1	16,0	18,0	9,5	43,0	17,2	36	1 5/16 - 18	41
		036	8-036	30,1	M26x1	24,5	28,0	18,5	43,0	18,2	36	1 5/16 - 18	41
		037	8-037	30,1	M30x1	28,5	32,0	21,5	43,0	18,2	36	1 5/16 - 18	41
		038	8-038	30,1	M36x1	34,5	38,0	27,5	43,0	18,2	36	1 5/16 - 18	41
		039	8-039	30,1	M39x1	38,0	41,0	30,5	43,0	18,2	36	1 5/16 - 18	41
22 24	24	24	9	32,7	M39x1	34,5	38,0	27,5	45,0	18,2	36	1 7/16 - 18	43
		040	9-040	32,7	M12x1	12,0	14,0	6,2	45,0	16,2	36	1 7/16 - 18	43
		041	9-041	32,7	M26x1	24,5	28,0	18,5	45,0	18,2	36	1 7/16 - 18	43
		042	9-042	32,7	M32x1	30,5	34,0	23,5	45,0	18,2	36,5	1 7/16 - 18	43
		043	9-043	32,7	M39x1	38,0	41,0	30,5	45,0	18,2	36,5	1 7/16 - 18	43

45° / 90° abgewinkelte Version auf Anfrage erhältlich /  
45° / 90° angled version available on request (BU1\*RMxxxx)

# 65821 / AA96912M / VG96912M

**Bandadapter**

für den Anschluss eines Schirmgeflechts, sowie für die Verwendung eines wärmeschrumpfenden Formteils

**Band adapter**

for braid termination and for use with a heat shrink boot

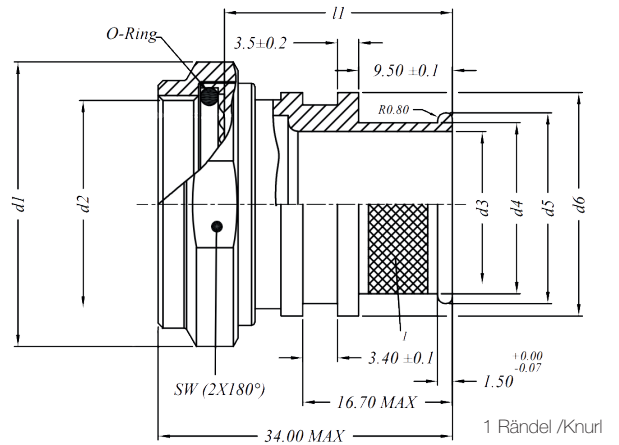

**Ergänzende Komponenten / Complementary components:**

Formteile / Heat shrink boot: VG95343  
 Befestigungsband / Bands: VG95319-1015  
 Spannwerkzeug / Bondingtool: VG95236-18

Beispiel / example:

VG96912M001J  
 65821-001-001J  
 AA96912M001

Gehäuse-Größe   Bauform Shell size   Shell style		Teilenummer / Dash-number		ØD1 ±0,2	D2 Gewinde / Thread UNEF-2B	ØD3 +0,5 -0,0	ØD4 ±0,1	ØD5 +0,0 -0,15	ØD6 +0,0 -0,15	L1 max.	SW
Einlochst.dose Jam nut rec.	Alle Anderen All others	VG	SJT								
-	8	001	1-001	19,0	7/16 - 28	19,0	22,5	23,3	24,5	24,51	17
8	10	002	2-002	22,0	9/16 - 24	9,5	13,0	13,8	15,0	22,5	20
8	10	003	2-003	22,0	9/16 - 24	22,0	24,8	25,6	28,3	24,51	20
10	12	004	3-004	25,0	11/16 - 24	25,0	28,5	29,3	32,0	24,51	23
12	14	005	4-005	28,0	13/16 - 20	15,5	19,0	19,8	21,0	22,50	26
12	14	006	4-006	28,0	13/16 - 20	17,5	21,0	21,8	23,0	22,50	26
14	16	012	5-012	30,0	15/16 - 20	15,9	19,4	20,2	21,4	24,51	28
14	16	007	5-007	30,0	15/16 - 20	28,5	32,0	32,8	35,5	24,51	28
16	18	008	6-008	34,0	1 1/16 - 18	22,0	24,8	25,6	28,3	23,50	32
18	20	009	7-009	38,0	1 3/16 - 18	25,0	28,5	29,3	32,0	26,52	36
20	22	010	8-010	43,0	1 5/16 - 18	12,7	16,5	17,0	18,2	26,52	41
22/24	24	011	9-011	45,0	1 7/16 - 18	17,5	21,0	21,8	23,0	26,52	43

## VG95319-1015 FORM / STYLE A

### Bänder

zur Befestigung von  
Schirmgeflechten am Bandadapter

### Ties

for termination of screening braids  
on the band adapter.

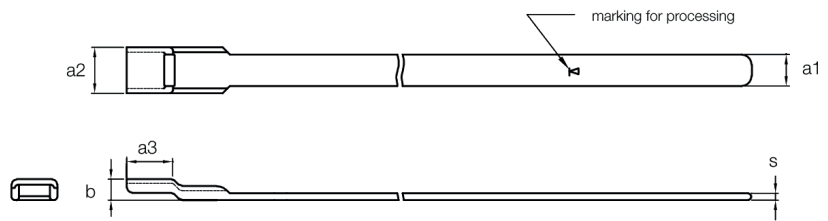

Beispiel / example:  
VG95319-1015A001



Teilenummer Part Number	a1 ± 0,25	a2 ± 0,76	a3 max.	b2 ± 0,38	s ± 0,08	Länge / Length min.	Bandadapter max. Ø	Spannwerkzeug Installation tool
VG95319-1015A001	6,22	8,89	4,0	1,88	0,48	360,00	47,80	VG95236T18A0001
VG95319-1015A002	6,22	8,89	4,0	1,88	0,48	455,00	63,80	VG95236T18A0001
VG95319-1015A003	2,92	4,95	2,30	1,35	0,38	204,00	22,40	VG95236T18A0002
VG95319-1015A004	2,92	4,95	2,30	1,35	0,38	354,00	47,80	VG95236T18A0002



Technische Eigenschaften / Technical specifications:	VG95319-1015
Material	Edelstahl, passiviert / Stainless steel, passivated
Verarbeitung gemäß / Processing acc. to	VG96927-4 4.9
Temperatureinsatzbereich / Operating temperature range	-46°C bis/to +200°C



### Plastic dust cap 37024

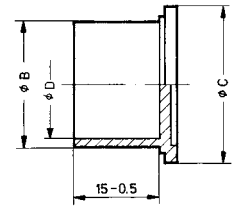

Dimensions in mm

Shell size	Order code (for plugs)	Dimensions in mm		
		$\phi B - 0.2$	$\phi C \pm 0.2$	$\phi D - 0.2$
8	S8	12.0	16.0	10
10	D8 S10	15.0	20.0	13.0
12	D10 S12	18.3	23.0	16.3
14	D12 S14	21.5	27.0	19.5
16	D14 S16	25.0	29.5	23.0
18	D16 S18	27.7	32.0	25.7
20	D18 S20	30.9	35.5	28.9
22	D20 S22	34.1	39.0	32.1
24	D22 S24	37.3	42.0	35.3

Shell size	Order code (for receptacles)	Dimensions in mm		
		$\phi B - 0.2$	$\phi C \pm 0.2$	$\phi D - 0.2$
8	D8 S10	15.0	20.0	13.0
10	D10 S12	18.3	23.0	16.3
12	D12 S14	21.5	27.0	19.5
14	D14 S16	25.0	29.5	23.0
16	D16 S18	27.7	32.0	25.7
18	D18 S20	30.9	35.5	28.9
20	D20 S22	34.1	39.0	32.1
22	D22 S24	37.3	42.0	35.3
24	D24	42.0	46.0	40.0

The dust caps protect the contacts during shipping and storage.



### Metal protective cap (for design type 06) (VG 96912 V3XX)

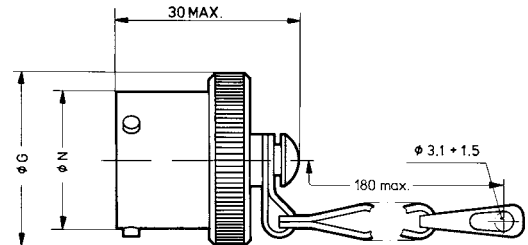

Dimensions in mm

Shell size	Order number		$\phi G$ max.	$\phi N$ + 0.03 - 0.13
	With link chain (Type A)	With nylon cord (Type B)		
8	42160-071	42162-071	17.5	12.01
10	42160-072	42162-072	20.6	14.99
12	42160-073	42162-073	24.6	19.05
14	42160-074	42162-074	27.8	22.23
16	42160-075	42162-075	31.0	25.40
18	42160-076	42162-076	34.1	28.58
20	42160-077	42162-077	37.3	31.75
22	42160-078	42162-078	40.5	34.93
24	42160-079	42162-079	43.7	38.10

The grommet is for attaching the protective cap. The protective cap is fitted with a seal which guarantees watertight sealing between the plug and the cap. Protective caps with other fastening types are available. Please send inquiry.



### Metal protective cap

(for design type 00)  
(VG 96912 V1XX)

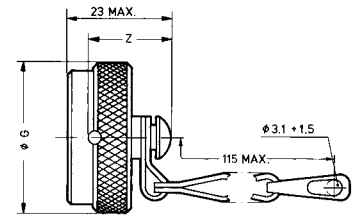

Dimensions in mm

Shell size	Order number		Dimensions in mm	
	With link chain (Type A)	With nylon cord (Type B)	ø G max.	Z max.
8	38822-071	38828-071	18.65	17.5
10	38822-072	38828-072	21.82	17.5
12	38822-073	38828-073	25.50	17.5
14	38822-074	38828-074	28.58	17.5
16	38822-075	38828-075	31.75	17.5
18	38822-076	38828-076	34.93	17.5
20	38822-077	38828-077	38.10	17.5
22	38822-078	38828-078	41.28	17.5
24	38822-079	38828-079	44.45	20.0

The protective cap is attached to one of the receptacle flange screws by means of a grommet. The protective cap is fitted with a seal which guarantees a splash-proof connection between cap and receptacle. Protective caps with other fastening types are available. Please send inquiry.



### Metal protective cap

(For design type 07)  
(VG 96912 V2XX)

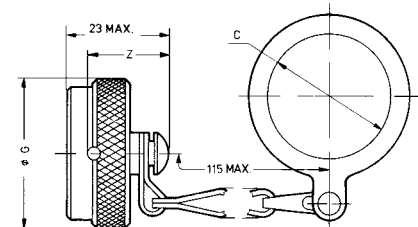

Dimensions in mm

Shell size	Order number		Dimensions in mm		
	With link chain (Type A)	With nylon cord (Type B)	ø C + 0.5 - 0.1	ø G max.	Z max.
8	38824-071	38826-071	14.7	18.7	17.5
10	38824-072	38826-072	17.9	21.9	17.5
12	38824-073	38826-073	22.6	25.5	17.5
14	38824-074	38826-074	25.8	28.6	17.5
16	38824-075	38826-075	29.0	31.8	17.5
18	38824-076	38826-076	32.2	35.0	17.5
20	38824-077	38826-077	35.3	38.1	17.5
22	38824-078	38826-078	38.5	41.3	17.5
24	38824-079	38826-079	41.7	44.5	20.0

The fastening ring of the protective cap attaches the cap to the receptacle. The protective cap is fitted with a seal which guarantees a splash-proof connection between cap and receptacle. Protective caps with other fastening types are available. Please send inquiry.

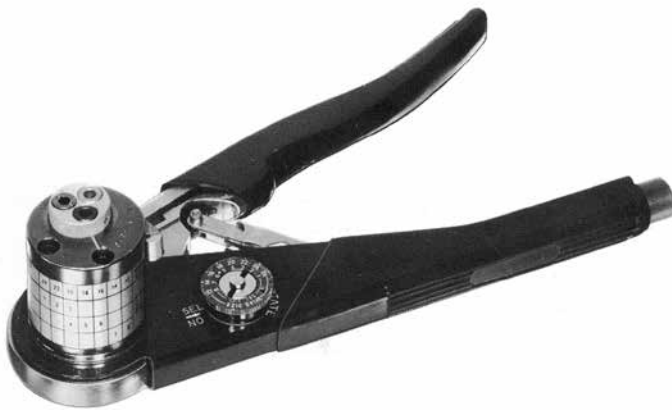

**Crimp tool M 22520/1-01**  
(8-notch crimping)

Dimensions in mm

Order code		Color code	Contact size	Wire size AWG
Crimp tool	Crimp insert			
M 22520/1-01	M 22520/1-04	red	20	20 to 24
		blue	16	16 to 20
		yellow	12	12 to 14

This tool allows the setting of eight different crimping depths depending on contact and wire size. Crimp tool and crimp insert must be ordered separately.



**Crimp tool M 22520/2-01**  
(8-notch crimping)

Dimensions in mm

Crimp tool	Order code		Contact size	Wire size AWG
	Pin contact	Socket contact		
M 22520/2-01	M 22520/2-09	M 22520/2-07	22 D	22 to 28
	M 22520/2-10		20	20 to 24

The crimp tool M 22520/2-01 allows the setting of eight different crimp depths depending on the contact sizes and wire size. Crimp tool and crimp insert must be ordered separately.

## Installation and removal tools for contacts



Straight type (preferable for design type 07)



Angled version

Contact size	Order number				Color designation	
	Installation tools		Removal Tools		Installation tools	Removal Tools
	Straight	Angled	Straight	Angled		
22 D	<b>11-8794-24</b> MS27495-A22MS	<b>11-8674-24</b> MS27495-A22M	<b>11-8795-24</b> MS27495-R22MS	<b>11-8675-24</b> MS27495-R22M	black	black-white
20	<b>11-8794-20</b> MS27495-A20S	<b>11-8674-20</b> MS27495-A20	<b>11-8795-20</b> MS27495-R20S	<b>11-8675-20</b> MS27495-R20	red	red-white
16	<b>11-8794-16</b> MS27495-A16S	<b>11-8674-16</b> MS27495-A16	<b>11-8795-16</b> MS27495-R16S	<b>11-8675-16</b> MS27495-R16	blue	blue-white
12	<b>11-8794-12</b> MS27495-A12S	<b>11-8674-12</b> MS27495-A12	<b>11-8795-12</b> MS27495-R12S	<b>11-8675-12</b> MS27495-R12	yellow	yellow-white



**Extraction tool**  
for unwired contacts

Contact size	Order number
22 D	36561-001
20	36561-003
16	36561-004
12	36561-005

**Assembly tool**  
for coupling connectors

Shell size	Order number
8 to 24	TG 69

## Contact crimping

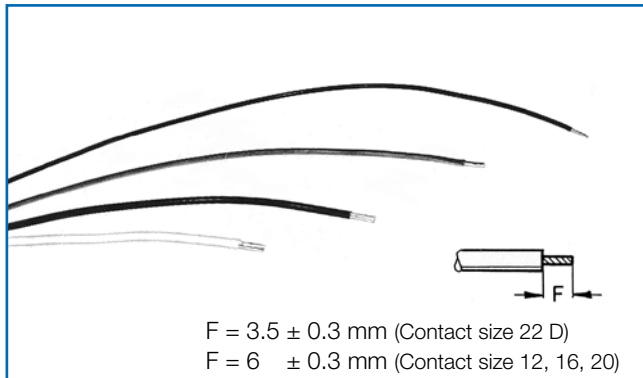

a Cut the conductor to the required length and strip it. The stranded wire must not be damaged. A heat-absorbing type is recommended.

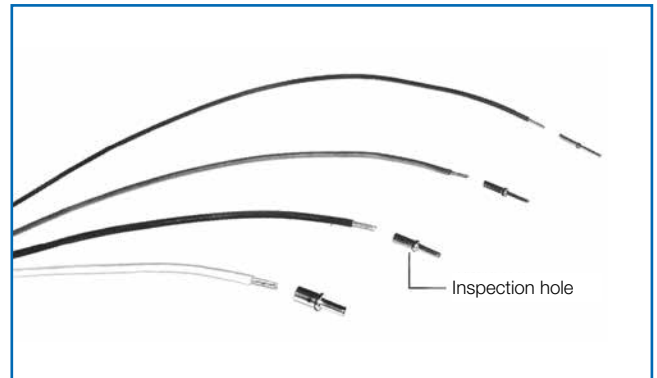

b Put the stripped wire into the contact crimp sleeve. Make sure that the stranded wire is visible through the inspection hole.



c The crimp tool M22520/1-01 (8-notch crimping) is equipped with a single insert (see p. 30), which allows the crimping of contacts in the sizes 12, 16, and 20. See also user manual provided by manufacturer.



d There are three crimp inserts for the crimp tools M22520/2-01 and MS 3198-1 (8-notch crimping) available (see p. 30). These allow crimping for contact sizes 22 and 22 D. See also user manual provided by manufacturer.



e After properly setting the wire size and contact size, close and reopen tool M 22520/1-01 to ensure that the crimp jaws are open. Insert contact with the conductor into receptacle. Close tool until it automatically reopens. Remove contact from the receptacle and check if conductor is visible through the inspection hole.



f After selecting the appropriate crimp insert, close and open the crimp tool M22520/2-01 or MS 3198-1 to make sure that the crimp jaws are open. Insert contact with conductor into receptacle. Close tool completely until it automatically reopens. Remove contact from the receptacle and check if conductor is visible through the inspection hole.

## Insertion of contacts

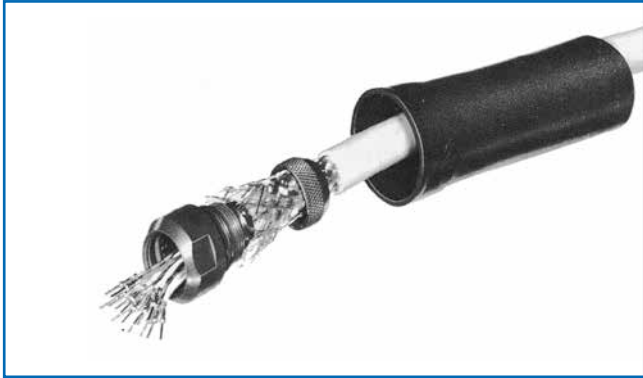

a Remove individual backshell components from the connector and place them over the wire bundles in the correct order.



b Use the appropriate tool to insert contacts into the connector (see p. 31).



c Place the tip of the insertion tool over the conductor up to the contact shoulder.

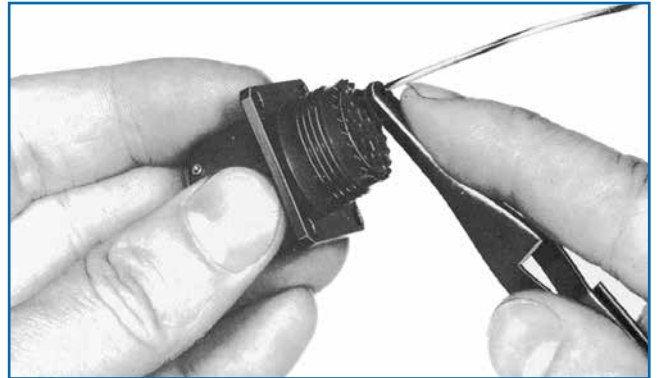

d Insert the contact on the back of the connector lineally and press forward until it clicks into place. Remove tool. By pulling gently on the conductor, check that the contact is correctly inserted.

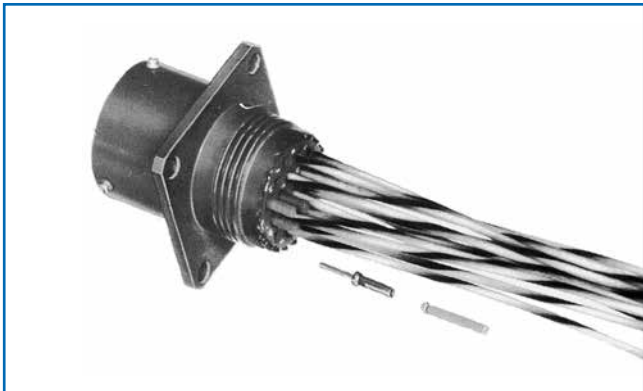

e Place an uncrimped contact and a sealing plug in unused contact openings. Put the sealing plug into the sealing insert in the manner shown above.



f After equipping the connector, determine by visual inspection if all contacts are inserted correctly. The backshell can then be screwed on.

### Mounting the backshell SQ

The backshell SQ (see p. 26) is used to hold the cable shielding braid through clamping or soldering, and for shrink-fitting a heat shrink part (see p. 38) as described to the right.

In conjunction with the plug SJTG 06 RT, which is equipped with a grounding ring (see p. 13), full shielding of the plug connection is achieved.

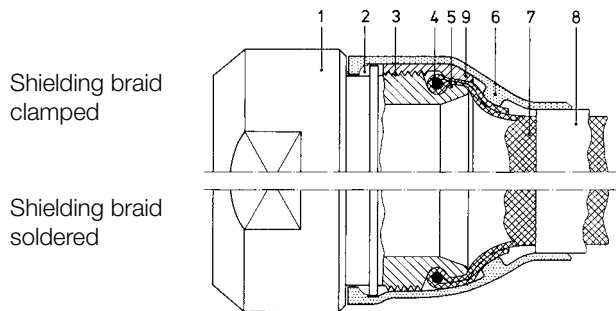

Backshell SQ with shielding braid and heat shrink part

### Clamping of shielding braid

- Before the shielding braid is clamped, screw the backshell with coupling ring (1) onto the wired connector until the teeth are engaged.
- Loosen the clamping nut (9). Place heat shrink part (6) and clamping nut over cables (8).
- Push shielding braid (7) onto backshell and over the thread (3).
- Fasten shielding braid (7) to the rounded groove with binding wire (4).
- Fold the protruding shielding braid back over the cone (5).
- Screw the clamping nut (9) onto the backshell (the folded shielding braid must protrude under the clamping nut on the cable side).
- Apply adhesive from the rectangular groove (2) down to the knurl of the clamping nut (9).
- Shrink-fit heat shrink part (6) (the lip of the heat shrink part grips into the rectangular groove (2)).

### Removal of wired contacts

- Detach backshell from connector.  
Select appropriate removal tool (see p. 31) according to contact size.
- Open removal tool and place it over the conductor, then push the tool into the connector axially until it stops. The tool must not be rotated or opened during this procedure.
- Hold the conductor, then remove the tool together with contact and conductor.

### Removal of unwired contacts

- Detach backshell from connector.
- Remove sealing plug.
- Select removal tool according to contact size (see p. 31) and push it into the back of the connector axially until it stops.
- Push the contact out of the connector from the front to the back side using the extraction tool 36561 (see p. 31).

With pin contacts, the extraction tool side marked with P is placed over the tip of the pin contact, and with socket contacts, the side marked S is pushed into the socket contact.

### Soldering of the shielding braid

Please send inquiry.

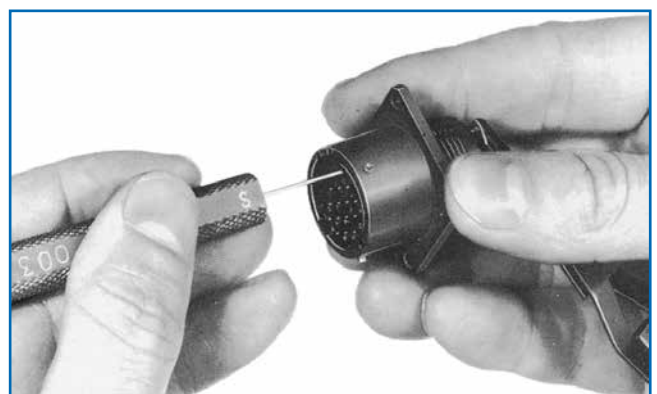

### Receptacles with square flange

Square flange receptacles can be mounted onto the front or back side of the mounting wall.

The respective flange gaskets on page 25 are to be used only for front wall mounting.

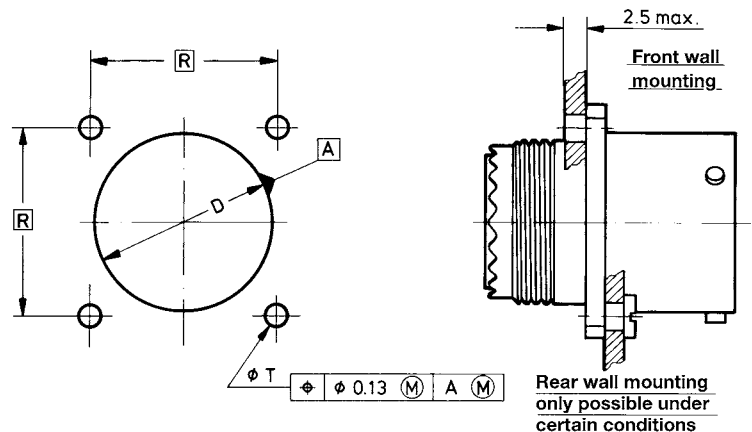

Dimensions in mm

Mounting hole

Installation example: SJT 00 RT

Shell size	8	10	12	14	16	18	20	22	24
$\varnothing D$ Front wall mounting	12.10	15.20	18.40	21.60	24.80	27.90	31.10	34.30	37.40
$\varnothing D$ Rear wall mounting	14.00	17.00	22.00	25.00	28.00	31.00	34.50	37.50	41.00
$\square R$ Theoretical dimensions	15.1	18.3	20.6	23.6	24.6	27.0	29.4	31.8	34.9
$\varnothing T \pm 0.3$	3.5	3.5	3.5	3.5	3.5	3.5	3.5	3.5	4.0

### Receptacles for single hole mounting

The receptacles for single hole mounting can be fixed to mounting walls with a thickness of 1.6 mm to 3.2 mm. The mounting nut torques are listed in the table below.

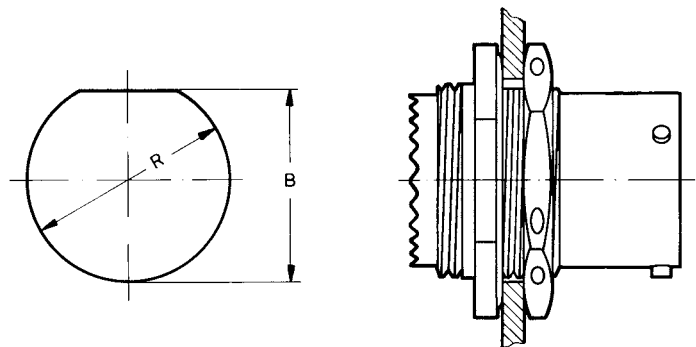

Dimensions in mm

Mounting hole

Installation example: SJT 07 RT

Shell size	8	10	12	14	16	18	20	22	24
$B - 0.25$	13.77	16.99	21.08	24.26	27.53	30.68	33.86	37.06	40.1
$\varnothing R + 0.25$	14.53	17.70	22.45	25.58	28.80	31.98	35.15	38.28	41.50
Max. torque Nm	3.6	4.1	5.6	6.8	8.5	9.6	10.7	12.4	13.6

### Hermetically sealed receptacle

The receptacle must be mounted in such a manner that the hermetic seal provided by the compression glass insert is maintained. The shell surface is tin-plated to facilitate soldering. Soldering tin with a low melting point is recommended. The solder is applied at the points indicated by arrows.

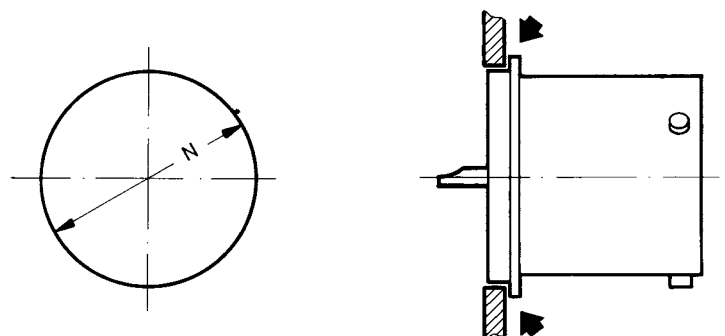

Dimensions in mm

Mounting hole

Installation example: SJT 07 RT

Shell size	8	10	12	14	16	18	20	22	24
$\varnothing N$ max.	14.78	17.58	20.35	23.52	26.70	29.87	32.30	35.30	38.61

### Receptacle SJT 00 RT and plug SJTG 06 RT with backshells

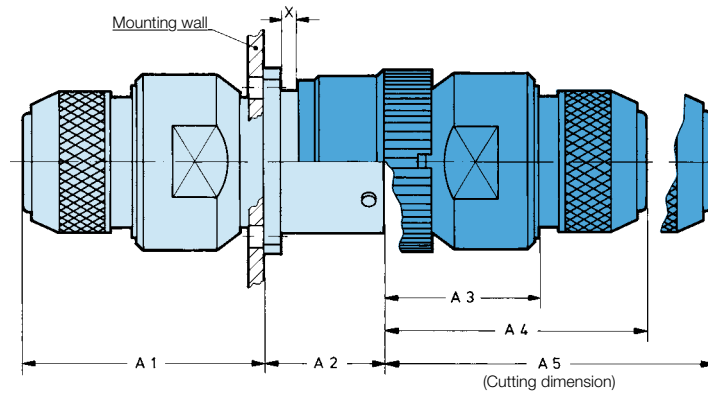

SJT 00 RT with backshell SQ

SJTG 06 RT with backshell SQ

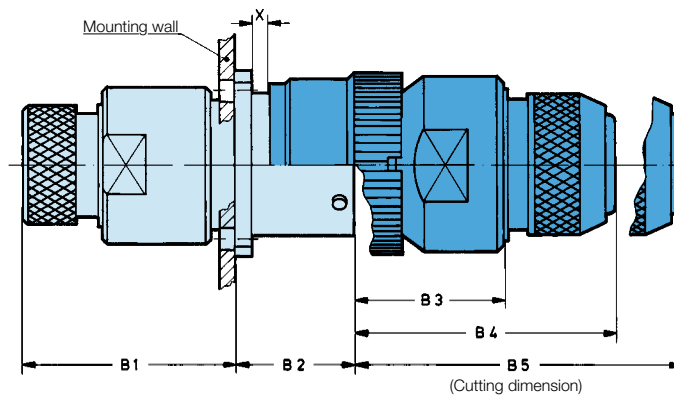

SJT 00 RT with backshell F

SJTG 06 RT with backshell SQ

Dimensions in mm

Shell size	A1	A2	A3	A4	A5	B1	B2	B3	B4	B5	X min.
8	39	18.4	26	42	58	33	18.4	26	42	58	3.1
10	39	18.4	26	42	58	33	18.4	26	42	58	3.1
12	39	18.4	26	42	58	33	18.4	26	42	58	3.1
14	39	18.4	26	42	58	33	18.4	26	42	58	3.1
16	39	18.4	27	43	59	33	18.4	27	43	59	3.1
18	39	18.4	27	43	59	33	18.4	27	43	59	3.1
20	39	18.4	27	43	59	33	18.4	27	43	59	2.3
22	39	18.4	27	43	59	33	18.4	27	43	59	2.3
24	40	18.4	27	43	59	35	18.4	27	43	59	1.5

## Receptacle SJT 07 RT and plug SJT 06 RT with backshells

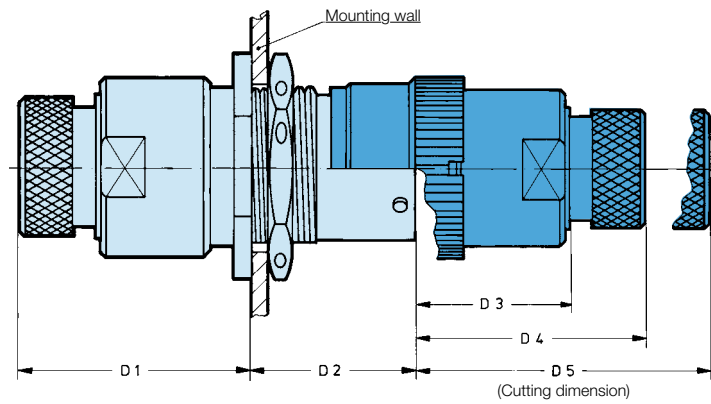
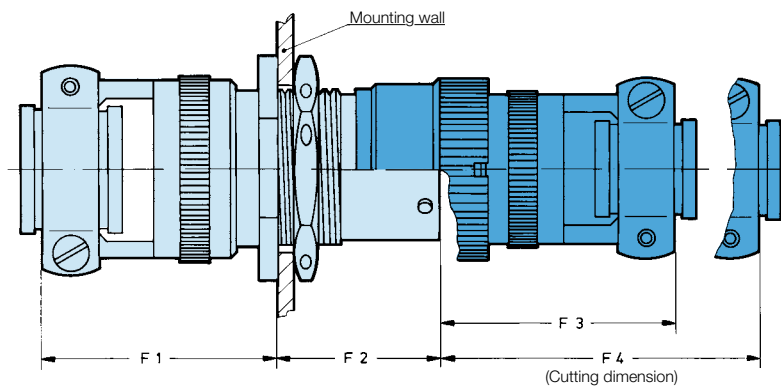
SJT 07 RT with  
backshell FSJT 06 RT with  
backshell FSJT 07 RT with  
strain release clampSJT 06 RT with  
strain release clamp

Dimensions in mm

Shell size	D1	D2	D3	D4	D5	F1	F2	F3	F4
8	34	23.4	25	37	53	30	23.4	33	49
10	34	23.4	25	37	53	30	23.4	33	49
12	34	23.4	25	37	53	30	23.4	33	49
14	34	23.4	25	37	53	36	23.4	39	55
16	34	23.4	25	37	53	36	23.4	39	55
18	35	23.4	25	37	53	37	23.4	39	55
20	35	23.4	25	37	53	40	23.4	42	58
22	35	23.4	25	37	53	40	23.4	42	58
24	35	23.4	26	38	54	40	23.4	43	59

## FORMSCHRUMPFTEILE / HEAT SHRINK BOOTS

Auswahl passender Formschrumpfteile / Selection of suitable heat shrink boots

Beschichtet mit Klebemittel / coated with adhesive

(Vollständige Übersicht siehe VG96927-5 Bbl.2 / For complete overview refer to VG96927-5 Bbl.2)

Endgehäuse / Backshell	gerades Formteil / straight boot	für Kabel / for Cable Ø min.	abgewinkeltes Formteil / angled boot	für Kabel / for Cable Ø min.
VG96912F1-8	VG95343T18B001A	6,2	VG95343T18D001A	6,2
VG96912F1-10	VG95343T18B001A	6,2	VG95343T18D001A	6,2
	VG95343T18B002A	3,6		
VG96912F1-12	VG95343T18B002A	3,6	VG95343T18D002A	6,5
	VG95343T18B003A	6,5		
VG96912F1-14	VG95343T18B002A	3,6	VG95343T18D002A	6,5
VG96912F1-16	VG95343T18B003A	6,5	VG95343T18D002A	6,5
	VG95343T18B004A	7,8	VG95343T18D003A	7,8
VG96912F1-18	VG95343T18B005A	9,2	VG95343T18D004A	9,2
VG96912F1-20	VG95343T18B005A	9,2	VG95343T18D004A	9,2
VG96912F1-22	VG95343T18B006A	10,9	VG95343T18D005A	10,9
	VG95343T18B007A	17,3	VG95343T18D006A	17,3
VG96912F1-24	VG95343T18B006A	10,9	VG95343T18D005A	10,9
	VG95343T18B007A	17,3	VG95343T18D006A	17,3

Endgehäuse / Backshell	gerades Formteil / straight boot	für Kabel / for Cable Ø min.	abgewinkeltes Formteil / angled boot	für Kabel / for Cable Ø min.
VG96912M001	VG95343T18B003A	6,5	VG95343T18D002A	6,5
	VG95343T18B004A	7,8	VG95343T18D003A	7,8
VG96912M002	VG95343T18B001A	6,2	VG95343T18D001A	6,2
VG96912M003	VG95343T18B004A	7,8	VG95343T18D003A	7,8
	VG95343T18B005A	9,2	VG95343T18D004A	9,2
VG96912M004	VG95343T18B005A	9,2	VG95343T18D004A	9,2
	VG95343T18B006A	10,9	VG95343T18D005A	10,9
VG96912M005	VG95343T18B002A	3,6	VG95343T18D002A	6,5
	VG95343T18B003A	6,5		
VG96912M006	VG95343T18B002A	3,6	VG95343T18D002A	6,5
	VG95343T18B003A	6,5		
VG96912M012	VG95343T18B002A	3,6	VG95343T18D002A	6,5
	VG95343T18B003A	6,5		
VG96912M007	VG95343T18B006A	10,9	VG95343T18D005A	10,9
VG96912M008	VG95343T18B004A	7,8	VG95343T18D003A	7,8
	VG95343T18B005A	9,2	VG95343T18D004A	9,2
VG96912M009	VG95343T18B005A	9,2	VG95343T18D004A	9,2
	VG95343T18B006A	10,9	VG95343T18D005A	10,9
VG96912M010	VG95343T18B002A	3,6	VG95343T18D002A	6,5
	VG95343T18B003A	6,5		
VG96912M010	VG95343T18B002A	3,6	VG95343T18D002A	6,5
	VG95343T18B003A	6,5		

Endgehäuse / Backshell	gerades Formteil / straight boot	für Kabel / for Cable Ø min.	abgewinkeltes Formteil/ angled boot	für Kabel / for Cable Ø min.
VG96912L8	VG95343T18B001A	6,2	VG95343T18D001A	6,2
VG96912L001	VG95343T18B002A	3,6	VG95343T18D002A	6,5
	VG95343T18B003A	6,5		
VG96912L10	VG95343T18B001A	6,2	VG95343T18D001A	6,2
VG96912L002	VG95343T18B001A	6,2	VG95343T18D001A	6,2
VG96912L003	VG95343T18B002A	3,6	VG95343T18D002A	6,5
	VG95343T18B003A	6,5		
VG96912L004	VG95343T18B002A	3,6	VG95343T18D002A	6,5
	VG95343T18B003A	6,5		
VG96912L005	VG95343T18B003A	6,5	VG95343T18D002A	6,5
	VG95343T18B004A	7,8	VG95343T18D003A	7,8
VG96912L006	VG95343T18B004A	7,8	VG95343T18D003A	7,8
	VG95343T18B005A	9,2	VG95343T18D004A	9,2
VG96912L12	VG95343T18B002A	3,6	VG95343T18D002A	6,5
	VG95343T18B003A	6,5		
VG96912L007	VG95343T18B001A	6,2	VG95343T18D001A	6,2
VG96912L008	VG95343T18B001A	5,6	VG95343T18D001A	6,2
VG96912L009	VG95343T18B002A	3,6	VG95343T18D002A	6,5
	VG95343T18B003A	6,5		
VG96912L010	VG95343T18B003A	6,5	VG95343T18D002A	6,5
	VG95343T18B004A	7,8	VG95343T18D003A	7,8
VG96912L011	VG95343T18B004A	7,8	VG95343T18D003A	7,8
	VG95343T18B005A	9,2	VG95343T18D004A	9,2
VG96912L14	VG95343T18B002A	3,6	VG95343T18D002A	6,5
	VG95343T18B003A	6,5		
VG96912L012	VG95343T18B001A	6,2	VG95343T18D001A	6,2
VG96912L013	VG95343T18B001A	6,2	VG95343T18D001A	6,2
VG96912L014	VG95343T18B002A	3,6	VG95343T18D002A	6,5
	VG95343T18B003A	6,5		
VG96912L015	VG95343T18B003A	6,5	VG95343T18D002A	6,5
	VG95343T18B004A	7,8	VG95343T18D003A	7,8
VG96912L016	VG95343T18B004A	7,8	VG95343T18D003A	7,8
	VG95343T18B005A	9,2	VG95343T18D004A	9,2
VG96912L16	VG95343T18B003A	6,5	VG95343T18D002A	6,5
	VG95343T18B004A	7,8	VG95343T18D003A	7,8
VG96912L017	VG95343T18B001A	6,2	VG95343T18D001A	6,2
VG96912L018	VG95343T18B002A	3,6	VG95343T18D002A	6,5
	VG95343T18B003A	6,5		
VG96912L019	VG95343T18B002A	3,6	VG95343T18D002A	6,5
	VG95343T18B003A	6,5		
VG96912L020	VG95343T18B004A	7,8	VG95343T18D003A	7,8
	VG95343T18B005A	9,2	VG95343T18D004A	9,2
VG96912L021	VG95343T18B005A	9,2	VG95343T18D004A	9,2
	VG95343T18B006A	10,9	VG95343T18D005A	10,9
VG96912L022	VG95343T18B006A	10,9	VG95343T18D005A	10,9

Endgehäuse / Backshell	gerades Formteil / straight boot	für Kabel / for Cable min. mm Ø	abgewinkeltes Formteil/ angled boot	für Kabel / for Cable min. mm Ø
VG96912L18	VG95343T18B004A	7,8	VG95343T18D003A	7,8
	VG95343T18B005A	9,4	VG95343T18D004A	9,4
VG96912L023	VG95343T18B002A	3,6	VG95343T18D002A	6,5
	VG95343T18B003A	6,5		
VG96912L024	VG95343T18B002A	3,6	VG95343T18D002A	6,5
	VG95343T18B003A	6,5		
VG96912L025	VG95343T18B003A	6,5	VG95343T18D002A	6,5
	VG95343T18B004A	7,8	VG95343T18D003A	7,8
VG96912L026	VG95343T18B005A	9,4	VG95343T18D004A	9,4
	VG95343T18B006A	10,9	VG95343T18D005A	10,9
VG96912L027	VG95343T18B006A	10,9	VG95343T18D005A	10,9
VG96912L028	VG95343T18B006A	10,9	VG95343T18D005A	10,9
	VG95343T18B007A	17,3	VG95343T18D006A	17,3
VG96912L20	VG95343T18B005A	9,4	VG95343T18D004A	9,4
	VG95343T18B006A	10,9	VG95343T18D005A	10,9
VG96912L029	VG95343T18B002A	3,6	VG95343T18D002A	6,5
	VG95343T18B003A	6,5		
VG96912L030	VG95343T18B002A	3,6	VG95343T18D002A	6,5
	VG95343T18B003A	6,5		
VG96912L031	VG95343T18B003A	6,5	VG95343T18D002A	6,5
	VG95343T18B004A	7,8	VG95343T18D003A	7,8
VG96912L032	VG95343T18B004A	7,8	VG95343T18D003A	7,8
	VG95343T18B005A	9,4	VG95343T18D004A	9,4
VG96912L033	VG95343T18B006A	10,9	VG95343T18D005A	10,9
VG96912L034	VG95343T18B006A	10,9	VG95343T18D005A	10,9
	VG95343T18B007A	17,3	VG95343T18D006A	17,3
VG96912L22	VG95343T18B006A	10,9	VG95343T18D005A	10,9
VG96912L035	VG95343T18B002A	3,6	VG95343T18D002A	6,5
	VG95343T18B003A	6,5		
VG96912L036	VG95343T18B004A	7,8	VG95343T18D003A	7,8
	VG95343T18B005A	9,4	VG95343T18D004A	9,4
VG96912L037	VG95343T18B005A	9,4	VG95343T18D004A	9,4
	VG95343T18B006A	10,9	VG95343T18D005A	10,9
VG96912L038	VG95343T18B006A	10,9	VG95343T18D005A	10,9
	VG95343T18B007A	17,3	VG95343T18D006A	17,3
VG96912L039	VG95343T18B006A	10,9	VG95343T18D005A	10,9
	VG95343T18B007A	17,3	VG95343T18D006A	17,3
VG96912L24	VG95343T18B006A	10,9	VG95343T18D005A	10,9
	VG95343T18B007A	17,3	VG95343T18D006A	17,3
VG96912L040	VG95343T18B001A	6,2	VG95343T18D001A	6,2
VG96912L041	VG95343T18B004A	7,8	VG95343T18D003A	7,8
	VG95343T18B005A	9,4	VG95343T18D004A	9,4
VG96912L042	VG95343T18B006A	10,9	VG95343T18D005A	10,9
VG96912L043	VG95343T18B006A	10,9	VG95343T18D005A	10,9
	VG95343T18B007A	17,3	VG95343T18D006A	17,3

**Contact bore holes for receptacles** (p. 18-20)

Front view of the pin insert in the normal position (p. 4)

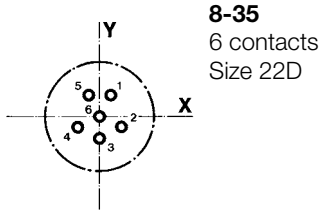

Contact	X	Y
1	+1.14	+1.98
2	+1.98	-1.14
3	0	-2.29
4	-1.98	-1.14
5	-1.14	+1.98
6	0	0

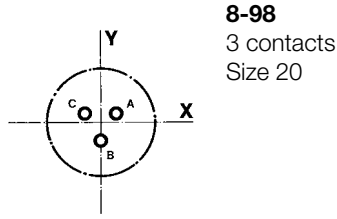

Contact	X	Y
A	+1.65	+0.97
B	0	-1.91
C	-1.65	+0.97

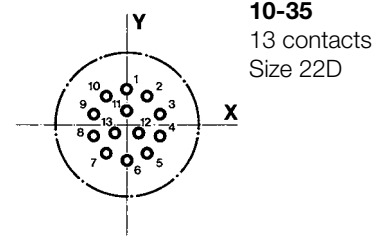

Contact	X	Y	Contact	X	Y
1	0	+3.71	8	-3.51	-1.14
2	+2.16	+3.00	9	-3.51	+1.14
3	+3.51	+1.14	10	-2.16	+3.00
4	+3.51	-1.14	11	0	+1.42
5	+2.16	-3.00	12	+1.24	-0.89
6	0	-3.71	13	-1.24	-0.89
7	-2.16	-3.00			

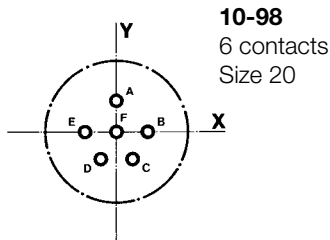

Contact	X	Y
A	0	+3.30
B	+3.30	0
C	+1.65	-2.87
D	-1.65	-2.87
E	-3.30	0
F	0	0

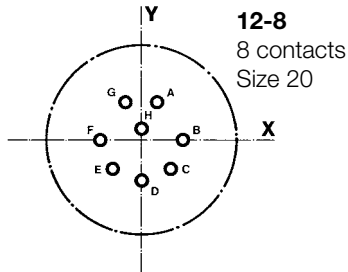

Contact	X	Y
A	+1.65	+3.99
B	+4.32	0
C	+3.05	-3.05
D	0	-4.32
E	-3.05	-3.05
F	-4.32	0
G	-1.65	+3.99
H	0	+1.12

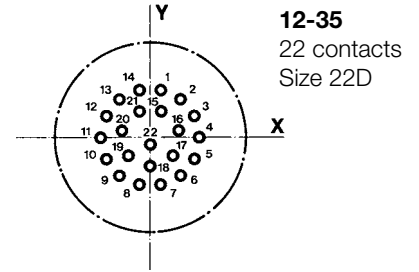

Contact	X	Y	Contact	X	Y
1	+1.14	+5.00	12	-4.62	+2.24
2	+3.20	+4.01	13	-3.20	+4.01
3	+4.62	+2.24	14	-1.14	+5.00
4	+5.16	0	15	+1.14	+2.72
5	+4.62	-2.24	16	+2.97	+0.66
6	+3.20	-4.01	17	+2.36	-1.91
7	+1.14	-5.00	18	0	-3.05
8	-1.14	-5.00	19	-2.36	-1.91
9	-3.20	-4.01	20	-2.97	+0.66
10	-4.62	-2.24	21	1.14	+2.72
11	-5.16	0	22	0	-0.76

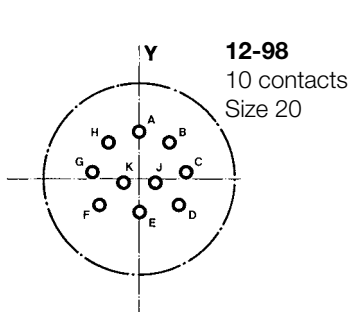

Contact	X	Y
A	0	+4.95
B	+3.18	+3.81
C	+4.90	+0.76
D	+4.17	-2.67
E	0	-3.43
F	-4.17	-2.67
G	-4.90	+0.76
H	-3.18	+3.81
J	+1.65	-0.38
K	-1.65	-0.38

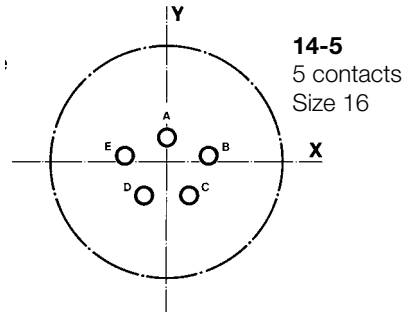

Contact	X	Y
A	0	+2.54
B	+4.42	+0.61
C	+2.39	-3.56
D	-2.39	-3.56
E	-4.42	+0.61

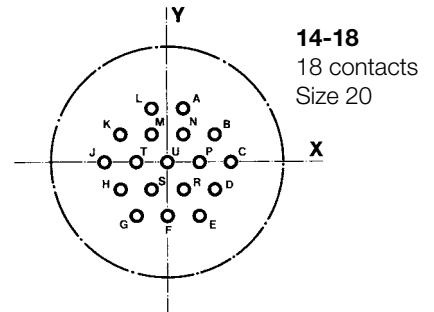

Contact	X	Y	Contact	X	Y
A	+1.65	+6.40	K	-4.95	+2.87
B	+4.95	+2.87	L	-1.64	+6.40
C	+6.60	0	M	-1.65	+2.87
D	+4.95	-2.87	N	+1.65	+2.87
E	+3.30	-5.72	P	+3.30	0
F	0	-5.72	R	+1.65	-2.87
G	-3.30	-5.72	S	-1.65	-2.87
H	-4.95	-2.87	T	-3.30	0
J	-6.60	0	U	0	0

**Contact bore holes for receptacles** (p. 18-20)  
 Front view of the pin insert in the normal position (p. 4)

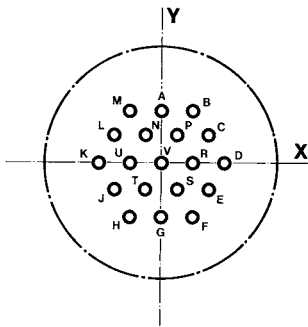

**14-19**  
 19 contacts  
 Size 20

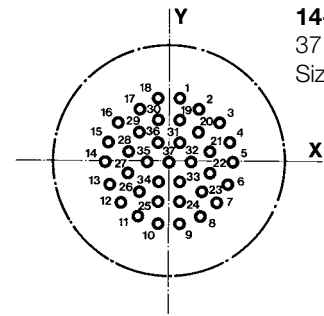

**14-35**  
 37 contacts  
 Size 22D

Contact	X	Y	Contact	X	Y
A	0	+5.72	L	- 4.95	+2.87
B	+3.30	+5.72	M	- 3.30	+5.72
C	+4.95	+2.87	N	- 1.65	+2.87
D	+6.60	0	P	+ 1.65	+2.87
E	+4.95	- 2.87	R	+3.30	0
F	+3.30	- 5.72	S	+ 1.65	- 2.87
G	0	- 5.72	T	- 1.65	- 2.87
H	- 3.30	- 5.72	U	- 3.30	0
J	- 4.95	- 2.87	V	0	0
K	- 6.60	0			

Contact	X	Y	Contact	X	Y
1	+1.14	+6.65	20	+ 3.12	+3.02
2	+3.12	+5.51	21	+ 4.32	+1.02
3	+5.36	+4.06	22	+ 4.32	- 1.27
4	+6.45	+2.03	23	+ 3.12	- 3.23
5	+6.76	- 0.25	24	+ 1.14	- 4.37
6	+6.27	- 2.49	25	- 1.14	- 4.37
7	+5.08	- 4.45	26	- 3.12	- 3.23
8	+3.30	- 5.89	27	- 4.32	- 1.27
9	+1.14	- 6.65	28	- 4.32	+1.02
10	- 1.14	- 6.65	29	- 3.12	+3.02
11	- 3.30	- 5.89	30	- 1.14	+4.37
12	- 5.08	- 4.45	31	+ 1.14	+1.88
13	- 6.27	- 2.49	32	+ 2.29	- 0.10
14	- 6.76	- 0.25	33	+ 1.14	- 2.08
15	- 6.45	+2.03	34	- 1.14	- 2.08
16	- 5.36	+4.06	35	- 2.29	- 0.10
17	- 3.12	+5.51	36	- 1.14	+1.88
18	- 1.14	+6.65	37	0	- 0.10
19	+1.14	+4.37			

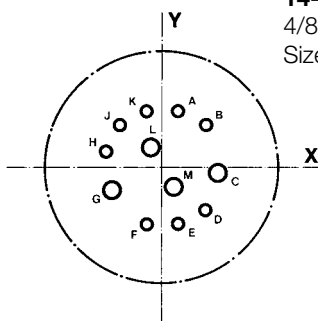

**14-97**  
 4/8 contacts  
 Size 16/20

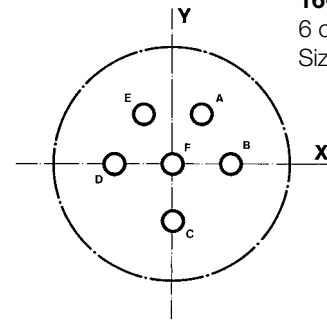

**16-6**  
 6 contacts  
 Size 12

Contact	X	Y
A	+ 1.65	+ 5.94
B	+ 4.52	+ 4.52
C	+ 5.84	- 0.58
D	+ 4.52	- 4.52
E	+ 1.65	- 5.94
F	- 2.26	- 5.96
G	- 5.26	- 2.41
H	- 5.94	+ 1.65
J	- 4.52	+ 4.52
K	- 1.65	+ 5.94
L	- 1.19	+ 2.06
M	+ 1.19	- 2.06

Contact	X	Y
A	+ 3.07	+ 5.31
B	+ 6.12	0
C	0	- 6.12
D	- 6.12	0
E	- 3.07	- 5.31
F	0	0

**Contact bore holes for receptacles** (p. 18-20)

Front view of the pin insert in the normal position (p. 4)

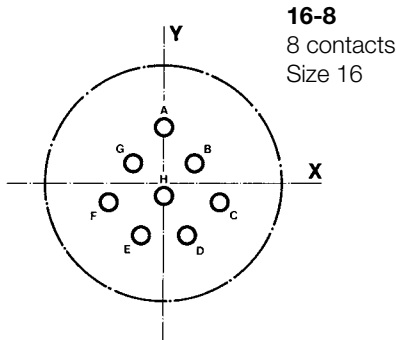

**16-8**  
8 contacts  
Size 16

Contact	X	Y
A	0	+5.99
B	+3.25	+2.18
C	+5.84	-1.98
D	+2.39	-5.49
E	-2.39	-5.49
F	-5.84	-1.98
G	-3.25	+2.18
H	0	-1.32

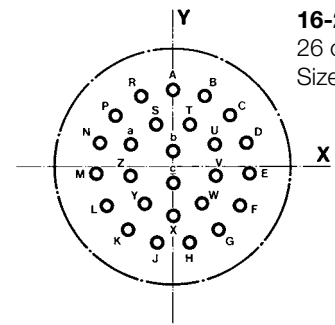

**16-26**  
26 contacts  
Size 20

Contact	X	Y	Contact	X	Y
A	0	+8.15	P	-6.07	+5.44
B	+3.33	+7.44	R	-3.33	+7.44
C	+6.07	+5.44	S	-1.78	+4.50
D	+7.75	+2.51	T	+1.78	+4.50
E	+8.10	-0.86	U	+4.45	+2.39
F	+7.06	-4.09	V	+4.52	-0.91
G	+4.80	-6.60	W	+3.02	-3.84
H	+1.70	-7.98	X	0	+5.16
J	-1.70	-7.98	Y	-3.02	-3.84
K	-4.80	-6.60	Z	-4.52	-0.91
L	-7.06	-4.09	a	-4.45	+2.39
M	-8.10	-0.86	b	0	+1.65
N	-7.75	+2.51	c	0	-1.65

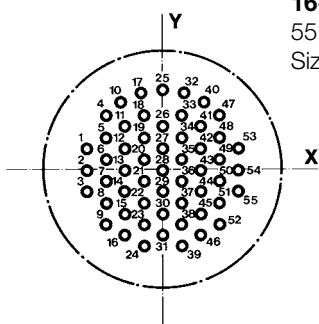

**16-35**  
55 contacts  
Size 22D

Contact	X	Y	Contact	X	Y
1	-7.92	+2.18	29	0	-2.39
2	-7.92	-0.10	30	0	-4.67
3	-7.92	-2.39	31	0	-6.96
4	-6.15	+5.61	32	+2.26	+8.03
5	-5.94	+3.33	33	+1.98	+5.61
6	-5.94	+1.04	34	+1.98	+3.33
7	-5.94	-1.24	35	+1.98	+1.04
8	-5.94	-3.53	36	+1.98	-1.24
9	-5.94	-5.82	37	+1.98	-3.53
10	-4.37	+7.09	38	+1.98	-5.82
11	-3.96	+4.47	39	+1.98	-8.10
12	-3.96	+2.18	40	+4.37	+7.09
13	-3.96	-0.10	41	+3.96	+4.47
14	-3.96	-2.39	42	+3.96	+2.18
15	-3.96	-4.67	43	+3.96	-0.10
16	-3.96	-6.96	44	+3.96	+2.39
17	-2.26	+8.03	45	+3.96	-4.67
18	-1.98	+5.61	46	+3.96	-6.96
19	-1.98	+3.33	47	+6.15	+5.61
20	-1.98	+1.04	48	+5.94	+3.33
21	-1.98	-1.24	49	+5.94	+1.04
22	-1.98	-3.53	50	+5.94	-1.24
23	-1.98	-5.82	51	+5.94	-3.53
24	-1.98	-8.10	52	+5.94	-5.82
25	0	+8.36	53	+7.92	+2.18
26	0	+4.47	54	+7.92	-0.10
27	0	+2.18	55	+7.92	-2.39
28	0	-0.10			

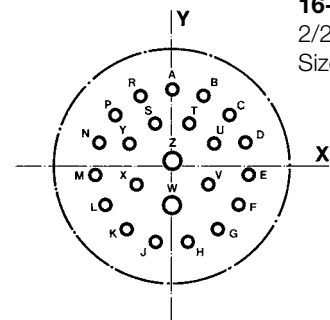

**16-99**  
2/21 contacts  
Size 16/20

Contact	X	Y	Contact	X	Y
A	0	+8.15	N	-7.75	+2.51
B	+3.33	+7.44	P	-6.07	+5.44
C	+6.07	+5.44	R	-3.33	+7.44
D	+7.75	+2.51	S	-1.78	+4.50
E	+8.10	-0.86	T	+1.78	+4.50
F	+7.06	-4.09	U	+4.45	+2.39
G	+4.80	-6.60	V	+3.81	-1.90
H	+1.70	-7.98	X	0	-6.60
J	-1.70	-7.98	Y	-3.81	-1.90
K	-4.80	-6.60	Z	-4.45	+2.39
L	-7.06	-4.09		0	+0.64
M	-8.10	-0.86			

**Contact bore holes for receptacles** (p. 18-20)  
 Front view of the pin insert in the normal position (p. 4)

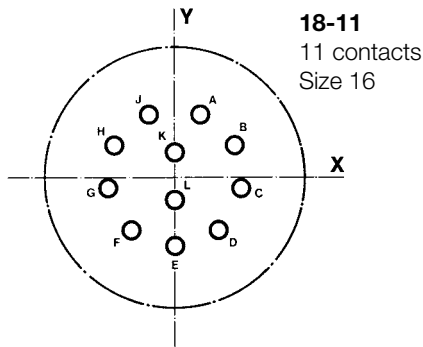

Contact	X	Y
A	+2.67	+6.60
B	+6.35	+3.35
C	+6.99	- 1.35
D	+4.55	- 5.46
E	0	- 7.14
F	- 4.55	- 5.46
G	- 6.99	- 1.35
H	- 6.35	+3.35
J	- 2.67	+6.60
K	0	+2.67
L	0	- 2.67

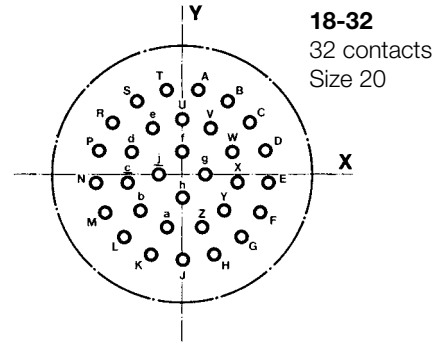

Contact	X	Y	Contact	X	Y
A	+1.68	+8.97	T	- 1.68	+8.97
B	+4.80	+7.75	U	0	+5.84
C	+7.26	+5.51	V	+3.15	+4.90
D	+8.76	+2.49	W	+5.31	+2.41
E	+9.07	- 0.84	X	+5.79	- 0.84
F	+8.15	- 4.06	Y	+4.42	- 3.84
G	+6.15	- 6.73	Z	+1.65	- 5.61
H	+3.30	- 8.51	a	- 1.65	- 5.61
J	0	- 9.12	b	- 4.42	- 3.84
K	- 3.30	- 8.51	c	- 5.79	- 0.84
L	- 6.15	- 6.73	d	- 5.31	+2.41
M	- 8.15	- 4.06	e	- 3.15	+4.90
N	- 9.07	- 0.84	f	0	+2.44
P	- 8.76	+2.49	g	+2.44	0
R	- 7.26	+5.51	h	0	- 2.44
S	- 4.80	+7.75	j	- 2.44	0

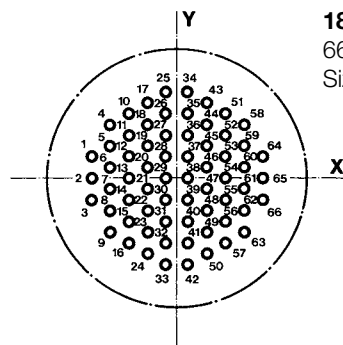

Contact	X	Y	Contact	X	Y	Contact	X	Y	Contact	X	Y
1	-9.07	+2.29	18	- 3.12	+5.72	35	+1.14	+6.86	52	+5.11	+4.57
2	-9.07	0	19	- 3.12	+3.43	36	+1.14	+4.57	53	+5.11	+2.29
3	-9.07	- 2.29	20	- 3.12	+1.14	37	+1.14	+2.29	54	+5.11	0
4	-7.09	+5.72	21	- 3.12	- 1.14	38	+1.14	0	55	+5.11	- 2.29
5	-7.09	+3.43	22	- 3.12	- 3.43	39	+1.14	- 2.29	56	+5.11	- 4.57
6	-7.09	+1.14	23	- 3.12	- 5.72	40	+1.14	- 4.57	57	+5.11	- 6.86
7	-7.09	- 1.14	24	- 3.12	- 8.00	41	+1.14	- 6.86	58	+7.09	+5.72
8	-7.09	- 3.43	25	- 1.14	+9.14	42	+1.14	- 9.14	59	+7.09	+3.43
9	-7.09	- 5.72	26	- 1.14	+6.86	43	+3.12	+8.00	60	+7.09	+1.14
10	-5.11	+6.86	27	- 1.14	+4.57	44	+3.12	+5.72	61	+7.09	- 1.14
11	-5.11	+4.57	28	- 1.14	+2.29	45	+3.12	+3.43	62	+7.09	- 3.43
12	-5.11	+2.29	29	- 1.14	0	46	+3.12	+1.14	63	+7.09	- 5.72
13	-5.11	0	30	- 1.14	- 2.29	47	+3.12	- 1.14	64	+9.07	+2.29
14	-5.11	- 2.29	31	- 1.14	- 4.57	48	+3.12	- 3.43	65	+9.07	0
15	-5.11	- 4.57	32	- 1.14	- 6.86	49	+3.12	- 5.72	66	+9.07	- 2.29
16	-5.11	- 6.86	33	- 1.14	- 9.14	50	+3.12	- 8.00			
17	-3.12	+8.00	34	+1.14	+9.14	51	+5.11	+6.86			

**Contact bore holes for receptacles** (p. 18-20)

Front view of the pin insert in the normal position (p. 4)

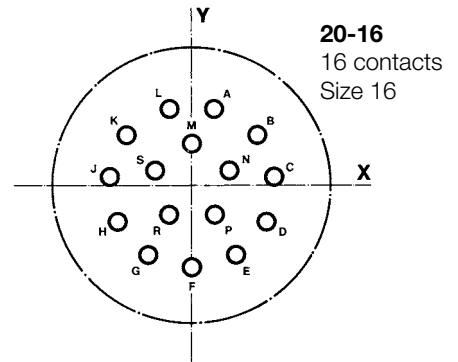
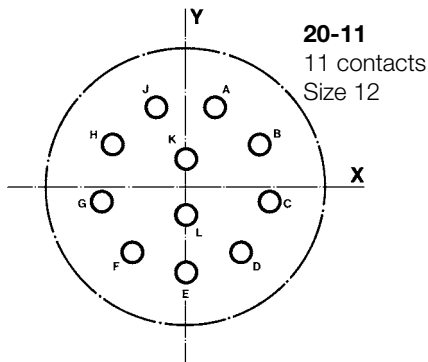

Contact	X	Y
A	+3.07	+8.43
B	+7.77	+4.50
C	+8.84	- 1.55
D	+5.77	- 6.86
E	0	- 8.97
F	- 5.77	- 6.86
G	- 8.84	- 1.55
H	- 7.77	+4.50
J	- 3.07	+8.43
K	0	+3.12
L	0	- 2.92

Contact	X	Y
A	+2.30	+8.18
B	+6.88	+5.36
C	+8.66	+0.91
D	+7.82	- 3.81
E	+4.62	- 7.37
F	0	- 8.71
G	- 4.62	- 7.37
H	- 7.82	- 3.81
J	- 8.66	+0.91
K	- 6.88	+5.36
L	- 2.30	+8.18
M	0	+4.45
N	+3.91	+1.57
P	+2.39	- 3.10
R	- 2.39	- 3.10
S	- 3.91	+1.57

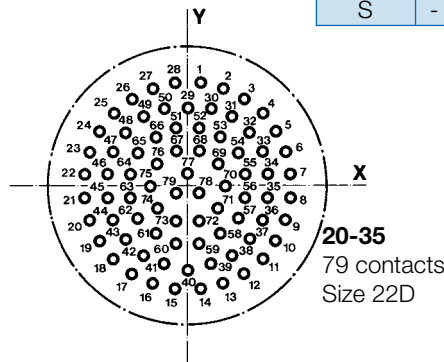

Contact	X	Y	Contact	X	Y	Contact	X	Y	Contact	X	Y
1	+ 1.35	+10.82	21	-10.85	- 1.22	41	- 2.49	- 8.18	61	- 3.40	- 5.05
2	+ 3.71	+10.26	22	-10.85	+ 1.22	42	- 4.67	- 7.11	62	- 5.28	- 3.53
3	+ 5.89	+ 9.19	23	-10.31	+ 3.58	43	- 6.55	- 5.59	63	- 6.02	- 1.22
4	+ 7.77	+ 7.67	24	- 9.27	+ 5.77	44	- 7.90	- 3.53	64	- 6.02	+1.22
5	+ 9.27	+ 5.77	25	- 7.77	- 7.67	45	- 8.43	- 1.22	65	- 5.28	+3.53
6	+10.31	+ 3.58	26	- 5.89	+ 9.19	46	- 8.43	+1.22	66	- 3.40	+5.05
7	+10.85	+ 1.22	27	- 3.71	+10.25	47	- 7.90	+3.58	67	- 1.22	+3.71
8	+10.85	- 1.22	28	- 1.35	+10.82	48	- 6.55	+5.59	68	- 1.22	+3.71
9	+10.31	- 3.58	29	0	+ 8.20	49	- 4.67	+7.11	69	+3.18	+2.29
10	+ 9.27	- 5.77	30	+ 2.49	+ 8.18	50	- 2.49	+8.18	70	+3.94	0
11	+ 7.77	- 7.67	31	+ 4.67	+ 7.11	51	- 1.22	+6.12	71	+3.18	- 2.29
12	+ 5.89	- 9.19	32	+ 6.55	+ 5.59	52	+1.22	+6.12	72	+1.22	- 3.71
13	+ 3.71	-10.26	33	+ 7.90	+ 3.58	53	+3.40	+5.05	73	- 1.22	- 3.71
14	+ 1.35	-10.82	34	+ 8.43	+ 1.22	54	+5.28	+3.53	74	- 3.18	- 2.29
15	- 1.35	-10.82	35	+ 8.43	- 1.22	55	+6.02	+1.22	75	- 3.94	0
16	- 3.71	-10.26	36	+ 7.90	- 3.58	56	+6.02	- 1.22	76	- 3.18	+2.29
17	- 5.89	- 9.19	37	+ 6.55	- 5.59	57	+5.28	- 3.53	77	0	+1.35
18	- 7.77	- 7.67	38	+ 4.67	- 7.11	58	+3.40	- 5.05	78	+ 1.22	- 0.74
19	- 9.27	- 5.77	39	+ 2.49	- 8.18	59	+1.22	- 6.12	79	- 1.22	- 0.74
20	-10.31	- 3.58	40	0	- 8.84	60	- 1.22	- 6.12			

**Contact bore holes for receptacles** (p. 18-20)

Front view of the pin insert in the normal position (p. 4)

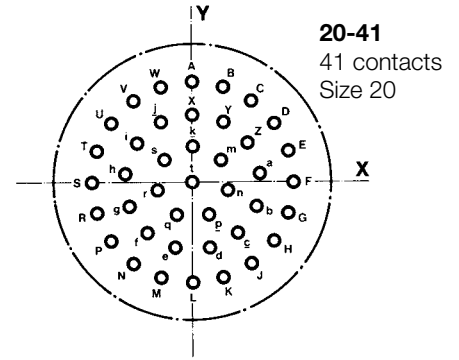
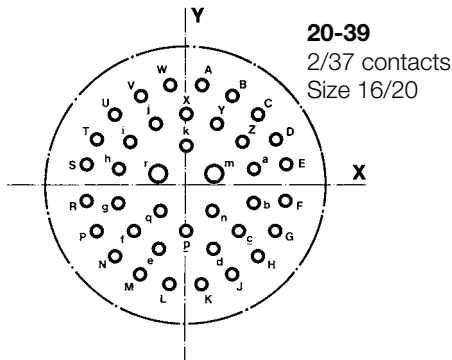

Contact	X	Y
A	+ 1.65	+10.44
B	+ 4.80	+ 9.42
C	+ 7.47	+ 7.47
D	+ 9.42	+ 4.80
E	+10.44	+ 2.16
F	+10.44	- 1.65
G	+ 9.42	- 4.80
H	+ 7.47	- 7.47
J	+ 4.80	- 9.42
K	+ 1.65	- 10.44
L	- 1.65	- 10.44
M	- 4.80	- 9.42
N	- 7.47	- 7.47
P	- 9.42	- 4.80
R	- 10.44	- 1.65
S	- 10.44	+ 2.16
T	- 9.42	+ 4.80
U	- 7.47	+ 7.47
V	- 4.80	+ 9.42
W	- 1.65	+10.44
X	0	+ 7.49
Y	+ 3.20	+ 6.50
Z	+ 5.89	+ 4.55
a	+ 7.11	+ 1.70
b	+ 7.11	- 1.80
c	+ 5.51	- 4.80
d	+ 2.84	- 6.73
e	- 2.84	- 6.73
f	- 5.51	- 4.80
g	- 7.11	- 1.88
h	- 7.11	+ 1.70
i	- 5.89	+ 4.55
j	- 3.20	+ 6.50
k	0	+ 4.17
m	+ 2.89	+ 1.22
n	+ 2.69	- 2.72
p	0	- 4.80
q	- 2.69	- 2.71
r	- 2.89	+ 1.22

Contact	X	Y	Contact	X	Y
A	0	+10.60	Y	+3.35	+6.38
B	+ 3.28	+10.09	Z	+5.92	+4.09
C	+ 6.23	+ 8.58	a	+7.15	+0.87
D	+ 8.58	+ 6.23	b	+6.73	- 2.55
E	+10.09	+ 3.28	c	- 4.78	- 5.39
F	+10.60	0	d	+1.73	- 6.99
G	+10.09	- 3.28	e	- 1.73	- 6.99
H	+ 8.58	- 6.23	f	- 4.78	- 5.39
J	+ 6.23	- 8.58	g	- 6.73	- 2.55
K	+ 3.28	- 10.09	h	- 7.15	+0.87
L	0	- 10.60	i	- 5.92	+4.09
M	- 3.28	- 10.09	j	- 3.35	+6.38
N	- 6.23	- 8.58	k	0	+3.81
P	- 8.58	- 6.23	m	+2.98	+2.38
R	- 10.09	- 3.28	n	+3.71	- 0.85
S	- 10.60	0	p	- 1.66	- 3.43
T	- 10.09	+ 3.28	q	+1.66	- 3.43
U	- 8.58	+ 6.23	r	- 3.71	- 0.85
V	- 6.23	+ 8.58	s	- 2.98	+2.38
W	- 3.28	+10.09	t	0	0
X	0	+ 7.20			

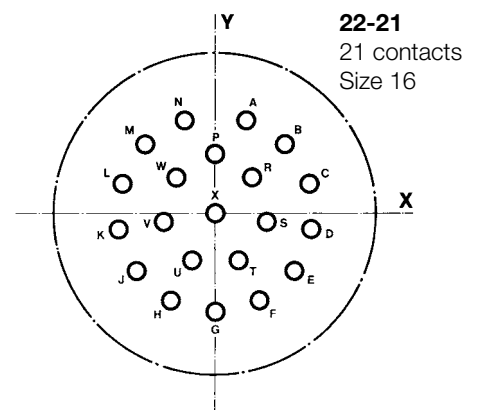

Contact	X	Y	Contact	X	Y
A	+ 3.25	+ 9.78	M	- 7.34	+7.24
B	+ 7.34	+ 7.24	N	- 3.25	+9.78
C	+ 9.80	+ 3.12	P	0	+6.22
D	+10.16	- 1.65	R	+4.06	+3.71
E	+ 8.33	- 6.07	S	+5.44	- 0.89
F	+ 4.65	- 9.19	T	+2.39	- 4.93
G	0	-10.31	U	- 2.39	- 4.93
H	- 4.65	- 9.19	V	- 5.44	- 0.89
J	- 8.33	- 6.07	W	- 4.06	+3.71
K	- 10.16	- 1.65	X	0	0
L	- 9.80	+ 3.12			

**Contact bore holes for receptacles** (p. 18-20)

Front view of the pin insert in the normal position (p. 4)

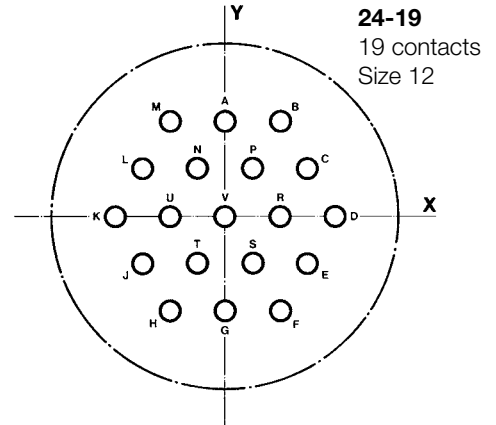
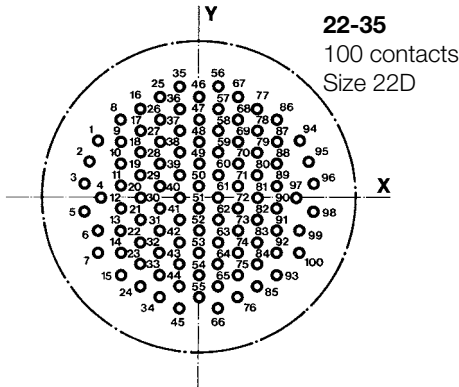

Contact	X	Y	Contact	X	Y
1	- 10.87	+ 6.12	51	0	- 1.19
2	- 11.86	+ 3.91	52	0	- 3.61
3	- 12.40	+ 1.55	53	0	- 6.02
4	- 10.54	0	54	0	- 8.43
5	- 12.40	- 1.55	55	0	- 10.85
6	- 10.87	- 3.61	56	+ 2.11	+12.07
7	- 10.87	- 6.02	57	+ 2.11	+ 9.65
8	- 8.43	+ 8.46	58	+ 2.11	+ 7.24
9	- 8.43	+ 6.05	59	+ 2.11	+ 4.83
10	- 8.43	+ 3.63	60	+ 2.11	+ 2.41
11	- 8.43	+ 1.22	61	+ 2.11	0
12	- 8.43	- 1.19	62	+ 2.11	- 2.41
13	- 8.43	- 3.61	63	+ 2.11	- 4.83
14	- 8.43	- 6.02	64	+ 2.11	- 7.24
15	- 8.43	- 8.43	65	+ 2.11	- 9.65
16	- 6.32	+ 9.65	66	+ 2.11	- 12.07
17	- 6.32	+ 7.24	67	+ 4.22	+10.87
18	- 6.32	+ 4.83	68	+ 4.22	+ 8.46
19	- 6.32	+ 2.41	69	+ 4.22	+ 6.05
20	- 6.32	0	70	+ 4.22	+ 3.63
21	- 6.32	- 2.41	71	+ 4.22	+ 1.22
22	- 6.32	- 4.83	72	+ 4.22	- 1.19
23	- 6.32	- 7.24	73	+ 4.22	- 3.61
24	- 6.32	- 9.65	74	+ 4.22	- 6.02
25	- 4.22	+10.87	75	+ 4.22	- 8.43
26	- 4.22	+ 8.46	76	+ 4.22	-10.85
27	- 4.22	+ 6.05	77	+ 6.32	+ 9.65
28	- 4.22	+ 3.63	78	+ 6.32	+ 7.24
29	- 4.22	+ 1.22	79	+ 6.32	+ 4.83
30	- 4.22	- 1.19	80	+ 6.32	+ 2.41
31	- 4.22	- 3.61	81	+ 6.32	0
32	- 4.22	- 6.02	82	+ 6.32	- 2.41
33	- 4.22	- 8.43	83	+ 6.32	- 4.83
34	- 4.22	- 10.85	84	+ 6.32	- 7.24
35	- 2.11	+12.07	85	+ 6.32	- 9.65
36	- 2.11	+ 9.65	86	+ 8.43	+ 8.46
37	- 2.11	+ 7.24	87	+ 8.43	+ 6.05
38	- 2.11	+ 4.83	88	+ 8.43	+ 3.63
39	- 2.11	+ 2.41	89	+ 8.43	+ 1.22
40	- 2.11	0	90	+ 8.43	- 1.19
41	- 2.11	2.41	91	+ 8.43	- 3.61
42	- 2.11	- 4.83	92	+ 8.43	- 6.02
43	- 2.11	- 7.24	93	+ 8.43	- 8.43
44	- 2.11	- 9.65	94	+10.87	+ 6.12
45	- 2.11	- 12.07	95	+11.86	+ 3.91
46	0	+10.87	96	+12.40	+ 1.55
47	0	+ 8.46	97	+10.54	0
48	0	+ 6.05	98	+12.40	- 1.55
49	0	+ 3.63	99	+10.87	- 3.61
50	0	+ 1.22	100	+10.87	- 6.02

Contact	X	Y	Contact	X	Y
A	0	+10.39	L	- 8.99	+ 5.21
B	+ 5.99	+10.39	M	- 5.99	+10.39
C	+ 8.99	+ 5.21	N	- 3.00	+ 5.21
D	+11.99	0	P	+3.00	+ 5.21
E	+ 8.99	- 5.21	R	+5.99	0
F	+ 5.99	- 10.39	S	+3.00	- 5.21
G	0	- 10.39	T	- 3.00	- 5.21
H	- 5.99	- 10.39	U	- 5.99	0
J	- 8.99	- 5.21	V	0	0
K	- 11.99	0			

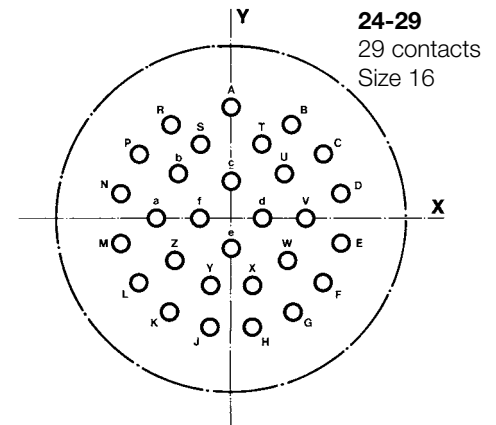

Contact	X	Y	Contact	X	Y
A	0	+12.22	S	- 2.31	+8.15
B	+ 6.55	+10.31	T	+2.31	+8.15
C	+10.03	+ 7.04	U	+5.79	+4.93
D	+11.91	+ 2.77	V	+8.10	0
E	+11.91	- 2.77	W	+6.10	- 4.60
F	+10.03	- 7.04	X	+2.31	- 7.37
G	+ 6.68	- 10.31	Y	- 2.31	- 7.37
H	+ 2.31	- 11.99	Z	- 6.10	- 4.60
J	- 2.31	- 11.99	a	- 8.10	0
K	- 6.68	- 10.31	b	- 5.79	+4.93
L	- 10.03	- 7.04	c	0	+4.09
M	- 11.91	- 2.77	d	+3.40	0
N	- 11.91	+ 2.77	e	0	- 3.30
P	- 10.03	+ 7.04	f	- 3.40	0
R	- 6.55	+10.31			

**Contact bore holes for receptacles** (p. 18-20)

Front view of the pin insert in the normal position (p. 4)

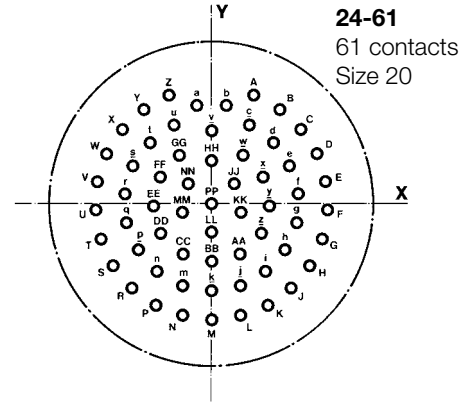
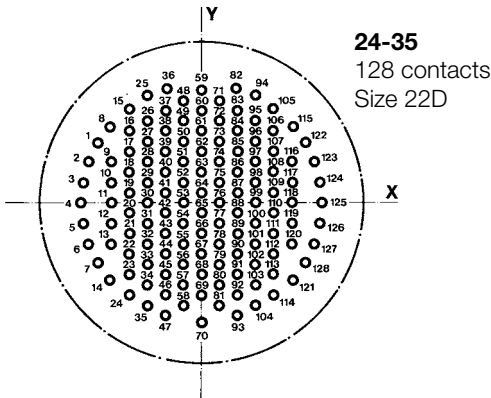

Contact	X	Y	Contact	X	Y
1	-12.17	+7.09	53	-2.11	0
2	-13.21	+4.83	54	-2.11	-2.41
3	-13.87	+2.41	55	-2.11	-4.83
4	-14.10	0	56	-2.11	-7.24
5	-13.87	-2.41	57	-2.11	-9.65
6	-13.21	-4.83	58	-2.11	-12.07
7	-12.17	-7.09	59	0	+13.26
8	-10.77	+9.07	60	0	+10.85
9	-10.54	+4.83	61	0	+8.43
10	-10.54	+2.41	62	0	+6.02
11	-10.54	0	63	0	+3.61
12	-10.54	-2.41	64	0	+1.19
13	-10.54	-4.83	65	0	-1.19
14	-10.77	-9.07	66	0	-3.61
15	-8.43	+11.28	67	0	-6.02
16	-8.43	+8.43	68	0	-8.43
17	-8.43	+6.02	69	0	-10.85
18	-8.43	+3.61	70	0	-14.10
19	-8.43	+1.19	71	+2.11	+12.07
20	-8.43	-1.19	72	+2.11	+9.65
21	-8.43	-3.61	73	+2.11	+7.24
22	-8.43	-6.02	74	+2.11	+4.83
23	-8.43	-8.43	75	+2.11	+2.41
24	-8.43	-10.85	76	+2.11	0
25	-6.32	+12.60	77	+2.11	-2.41
26	-6.32	+9.65	78	+2.11	-4.83
27	-6.32	+7.24	79	+2.11	-7.24
28	-6.32	+4.83	80	+2.11	-9.65
29	-6.32	+2.41	81	+2.11	-12.07
30	-6.32	0	82	+4.06	+13.49
31	-6.32	-2.41	83	+4.22	+10.85
32	-6.32	-4.83	84	+4.22	+8.43
33	-6.32	-7.24	85	+4.22	+6.02
34	-6.32	-9.65	86	+4.22	+3.61
35	-6.32	-12.07	87	+4.22	+1.19
36	-4.06	+13.49	88	+4.22	-1.19
37	-4.22	+10.85	89	+4.22	-3.61
38	-4.22	+8.43	90	+4.22	-6.02
39	-4.22	+6.02	91	+4.22	-8.43
40	-4.22	+3.61	92	+4.22	-10.85
41	-4.22	+1.19	93	+4.22	-13.26
42	-4.22	-1.19	94	+6.32	+12.60
43	-4.22	-3.61	95	+6.32	+9.65
44	-4.22	-6.02	96	+6.32	+7.24
45	-4.22	-8.43	97	+6.32	+4.83
46	-4.22	-10.85	98	+6.32	+2.41
47	-4.22	-13.26	99	+6.32	0
48	-2.11	+12.07	100	+6.32	-2.41
49	-2.11	+9.65	101	+6.32	-4.83
50	-2.11	+7.24	102	+6.32	-7.24
51	-2.11	+4.83	103	+6.32	-9.65
52	-2.11	+2.41	104	+6.32	-12.07

Contact	X	Y	Contact	X	Y
A	+4.98	+12.70	i	+6.38	-7.98
B	+7.98	+11.05	j	+3.38	-9.63
C	+10.49	+8.71	k	0	-10.21
D	+12.32	+5.84	m	-3.38	-9.63
E	+13.39	+2.57	n	-6.38	-7.98
F	+13.61	-0.76	p	-8.66	-5.41
G	+12.98	-4.17	q	-9.96	-2.24
H	+11.53	-7.29	r	-10.13	+1.17
J	+9.35	-9.93	s	-9.19	+4.45
K	+6.58	-11.94	t	-7.24	+7.19
L	+3.40	-13.18	u	-4.39	+9.22
M	0	-13.64	v	0	+8.59
N	-3.40	-13.18	w	+3.73	+5.66
P	-6.58	-11.94	x	+6.02	+3.10
R	-9.35	-9.93	y	+6.78	-0.25
S	-11.53	-7.29	z	+5.79	-3.53
T	-12.98	-4.17	AA	+3.33	-5.92
U	-13.61	-0.76	BB	0	-6.78
V	-13.39	+2.57	CC	-3.33	-5.92
W	-12.32	+5.84	DD	-5.79	-3.53
X	-10.49	+8.71	EE	-6.78	-0.25
Y	-7.98	+11.05	FF	-6.02	+3.10
Z	-4.98	+12.70	GG	-3.73	+5.66
a	-1.73	+11.53	HH	0	+5.08
b	+1.73	+11.53	JJ	+2.67	+2.39
c	+4.39	+9.22	KK	+3.43	-1.04
d	+7.24	+7.19	LL	0	-3.35
e	+9.19	+4.45	MM	-3.43	-1.04
f	+10.13	+1.17	NN	-2.67	+2.39
g	+9.96	-2.24	PP	0	0
h	+8.66	-5.41			

Contact	X	Y	Contact	X	Y
105	+8.43	+11.28	117	+10.54	+2.41
106	+8.43	+8.43	118	+10.54	0
107	+8.43	+6.02	119	+10.54	-2.41
108	+8.43	+3.61	120	+10.54	-4.83
109	+8.43	+1.19	121	+10.77	-9.07
110	+8.43	-1.19	122	+12.17	+7.09
111	+8.43	-3.61	123	+13.21	+4.83
112	+8.43	-6.02	124	+13.87	+2.41
113	+8.43	-8.43	125	+14.10	0
114	+8.43	-10.85	126	+13.87	-2.41
115	+10.77	+9.07	127	+13.21	-4.83
116	+10.54	+4.83	128	+12.17	-7.09

Amphenol-Air LB GmbH, Am Kleinbahnhof 4, D-66740 Saarlouis  
Telephone +49(0)6831 9810-0 · Telefax +49(0)6831 9810-20 · E-mail: [info@amphenol-airlb.de](mailto:info@amphenol-airlb.de)  
<http://www.amphenol-airlb.de>